



DHA...EC CP 20 / ...EC O CP S



Roof fan with constant pressure control



Made in EU



Example configuration shown

CONTENTS

1.	FOREWORD	2
2.	IMPORTANT INFORMATION	2
3.	GENERAL SAFETY INSTRUCTIONS	3
4.	ADHERE TO THE FOLLOWING INSTRUCTIONS	6
5.	PRODUCT INFORMATION	6
6.	DELIVERY CONTENTS	7
7.	TECHNICAL DATA	7
8.	DIMENSIONS	8
9.	TRANSPORT AND STORAGE	8
10.	ASSEMBLY	9
11.	ELECTRICAL CONNECTION	13
12.	COMMISSIONING	15
13.	OPERATION	15
14.	MAINTENANCE AND CLEANING	21
15.	LIFETIME AND DISPOSAL	22
16.	TROUBLESHOOTING	22

ruck Ventilatoren GmbH
Max-Planck-Str. 5
D-97944 Boxberg-Windischbuch
Tel. +49 7930 9211-300
Fax +49 7930 9211-166
info@ruck.eu
www.ruck.eu

The original instructions were created in the German language.

Information updated
print 08.03.2023
Subject to change

1. FOREWORD

Dear customers,

Thank you for choosing our device.

Before operating the unit, please read carefully these installation, operating and maintenance instructions. If you have any questions, please contact: (Contact details see page 1)

The data provided in these installation, operating and maintenance instructions are for the product description only. A statement about a certain condition or a suitability for a certain application cannot be derived from our information. The information does not release the user from his own assessments and examinations.

All rights reserved by the manufacturer, even in the event of industrial property rights.

Any disposal such as copying and distribution rights lies with us.

2. IMPORTANT INFORMATION

This manual contains important information on the safe and appropriate assembly, transport, commissioning, operation, maintenance, disassembly and simple troubleshooting of the product.

The product has been manufactured according to the accepted rules of current technology.

There is, however, still a danger of personal injury or damage to equipment if the following general safety instructions and the warnings before the steps contained in these instructions are not complied with.

- Read these instructions completely and thoroughly before working with the product.
- Keep these instructions in a location where they are accessible to all users at all times.
- Always include the operating instructions when you pass the product on to third parties.

2.1. Applicable Documents

The following documents and information on the exhaust fan must be observed in addition to the installation, operating and maintenance instructions:

Nameplate

Other applicable standards:

- DIN VDE 0100-100
- DIN EN 60204-1
- DIN EN ISO 13857
- DIN EN ISO 12100
- VDMA 24186-1

Available documents at www.ruck.eu

- Installation, operating and maintenance instructions
- Programming instruction FU (three-phase version)
- EC Declarations of conformity
- EC-Declaration of Incorporation (Directive 2006/42/EC)
- Commissioning report
- Call to Tender
- Dimensioned drawing
- Technical drawing DWG
- Technical drawing DXF
- 3D STEP

2.2. Provisions and regulations

When properly installed and operated, the device complies with the applicable standards and EU Directive at the time of its placing on the market.

In addition, observe generally valid, legal and other binding regulations of the European or national legislation as well as the regulations in your country for accident prevention and environmental protection.

2.3. Warranty and liability

Our devices are manufactured to the highest technical level in accordance with the generally accepted rules of technology. They are subject to constant quality controls. Because the products are being constantly developed, we reserve the right to make changes to the products at any time and without prior announcement. We assume no liability for the correctness or completeness of these installation, operating and maintenance instructions.

To ensure your warranty claims, it is imperative to provide a commissioning report and a maintenance record.

Warranty and liability claims for personal injury and property damage are excluded if they are due to one or more of the following causes:

- Improper use
- Improper mounting, commissioning, operation and maintenance
- Operating the device with defective and / or non-functional safety and protective devices
- Failure to observe the instructions regarding transportation, installation, operation and maintenance
- Unauthorized structural changes to the device
- Poor monitoring and replacement of maintenance parts
- Improperly performed repairs
- Disasters and force majeure

3. GENERAL SAFETY INSTRUCTIONS

Planners, plant engineers and operators are responsible for ensuring that the product is installed and operated correctly.

- Use our devices only in perfect technical condition.
- Check the device for obvious defects, such as cracks in the housing or missing rivets, screws, caps or other application-relevant defects.
- Only use the device in the power range specified in the technical data and on the nameplate.
- Protection against contact and being sucked in and safety distances should be provided in accordance with DIN EN 13857.
- Generally prescribed electrical and mechanical protection devices are to be provided by the client.
- Safety components must not be bypassed or put out of operation.
- The product may be operated by personnel with limited physical, sensory or mental capacities only if they are supervised or have been instructed by responsible personnel.
- Children must be kept away from the product.

3.1. Intended use

Our devices are incomplete machineries as defined in the EU Machinery Directive 2006/42/EC (partly completed machinery). The product is a not ready-for-use machine in terms of the machine directive.

It is intended exclusively for installation in a machine or in ventilation equipment and installations or for combination with other components to form a machinery or installation. The product may be commissioned only if it is integrated in the machinery/system for which it is designed and the machinery/system fully complies with the EC machinery directive.

Observe the operating conditions and performance limits specified in the technical data.

Conveying and ambient temperatures must be observed according to the technical data and the nameplate.

Intended use also implies that you have fully read and understood this manual.



Improper use may result in danger to the life and limb of the user or third parties or damage to the system or other property.

3.2. Improper use

Any use of the product other than described in chapter "Intended use" is considered as improper.

The following points are improper and dangerous:

- Delivery of explosive and flammable media or operation in potentially explosive atmospheres.
- The conveyance of greasy and moist media (over 90% relative humidity).
- Delivery of aggressive and abrasive media.
- Operation without the duct system.
- Operation with closed air connections.
- The use on vehicles, aircrafts and ships.

3.3. Personnel qualifications

Assembly, commissioning, operation, disassembly and service (including maintenance and repair) require basic mechanical and electrical knowledge, as well as knowledge of the appropriate technical terms. In order to ensure operating safety, these activities may therefore only be carried out by qualified technical personnel or a person under the direction and supervision of qualified personnel. Qualified personnel are those who can recognize possible hazards and institute the appropriate safety measures due to their professional training, knowledge, and experience, as well as their understanding of the relevant conditions pertaining to the work to be done. Qualified personnel must observe the rules relevant to the subject area.

3.4. Safety instructions in this manual

In this manual, there are safety instructions before the steps whenever there is a danger of personal injury or damage to the equipment. The measures described to avoid these hazards must be observed.

Safety instructions are set out as follows:

Safety sign (warning triangle)

- Draws attention to the risk.

● Type of risk!

- Identifies the type or source of the hazard.

» Consequences

- Describes what occurs when the safety instructions are not complied with.

→ Precautions

- States how the hazard can be avoided.

Safety sign (warning triangle)



General warning!

Indicates possible hazardous situations. Failure to observe the warnings may result in personal injury and / or damage to property.



Electricity warning (hazardous voltage)!

Indicates possible hazards due to electricity. Failure to observe the warnings may result in death, injury and/or damage to property.



Hot surface warning!

Indicates possible hazards due to high surface temperatures. Failure to observe the warnings may result in personal injury and/or damage to property.



Finger-Crushing Warning!

Indicates possible hazards due to moving and rotating parts. Failure to observe the warnings may result in personal injury.



Overhead load warning!

Indicates possible hazards due to overhead loads. Failure to observe the warnings may result in death, injury and/or damage to property.



Follow important information!

Instructions for safe, optimum use of the product.



● General warning

- » Failure to observe the warnings may result in personal injury and / or damage to property.
- Unauthorized repairs may cause personal injury and / or damage to property, in which case the manufacturer's guarantee or warranty will not apply.



● Electricity warning (hazardous voltage)!

- » Failure to observe the hazard may result in death, injury or damage to property.
- Before performing any work on conductive parts, always disconnect the unit completely from the electricity supply and make sure that it cannot be switched back on again.



● Caution! Burning hazard.

- » Failure to observe the hazard may result in personal injury and/or damage to property.
- Do not touch the surface until the motor and heater have cooled.



● Never reach into the impeller or other rotating or moving parts.

- » Failure to observe the hazard may lead to serious injury.
- Work may only be performed once the impeller has come to a complete halt.



● Never reach into the impeller or other rotating or moving parts.

- » Failure to observe the hazard may lead to serious injury.
- Work may only be performed once the impeller has come to a complete halt.



● Never clean the internal space with flowing water or a high-pressure cleaner. Do not use aggressive or easily flammable products for cleaning (impellers/housing).

- Only use mild soapsuds. The impeller should be cleaned with a cloth or brush.

4. ADHERE TO THE FOLLOWING INSTRUCTIONS

4.1. General instructions

- Persons who assemble, operate, disassemble or maintain our devices must not be under the influence of alcohol, drugs or pharmaceuticals that may affect perception and responsiveness.
- Responsibilities for the operation, maintenance and regulation of the product should be clearly determined and observed so that there can be no unclear areas of responsibility with regard to safety.

4.2. Indications assembly

- Disconnect all of the product's poles from the mains before installing the product or connecting or removing plugs. Make sure that the product cannot be switched back on again.
- Lay cables and lines so that they cannot be damaged and no one can trip over them.
- Information signs must not be changed or removed.

4.3. Indications Commissioning

- Make sure that all electrical connections are either used or covered. Commission the product only if it is installed completely.
- The power switch must always be fully functional and easy accessible!

4.4. Indications during operation

- Only authorized personnel is allowed to operate the setting mechanisms of the components or parts, under the provision that the system is used as intended.
- In an emergency, or if there is a fault, or other irregularities, switch the equipment off and make sure it cannot be switched back on again.
- The technical data given on the rating plate must not be exceeded.

5. PRODUCT INFORMATION

Description:

- Roof fan with constant pressure control
 - The temperature of the conveying medium of the individual types can be found in the technical data
 - Horizontal discharge
 - Backward curved radial impeller
 - Motor inside the airflow
 - Integrated thermal motor monitoring
 - Power switch integrated
 - Outdoor installation over heated rooms
 - Installation position vertical
 - Snow load class 0
 - Connection flange dimensions according to DIN 24154R3
 - The housing is made of plastic
 - Electronically commutated (EC) external rotor motor.
-
- The roof fan with constant pressure control is used in ventilation systems to maintain a constant set pressure level.
 - The constant pressure control is integrated in the air handling unit housing. It controls the fan speed to reach and keep the set-point of the differential pressure constant.

5.1. Nameplate

ATTENTION! The information on the nameplate must always be observed!

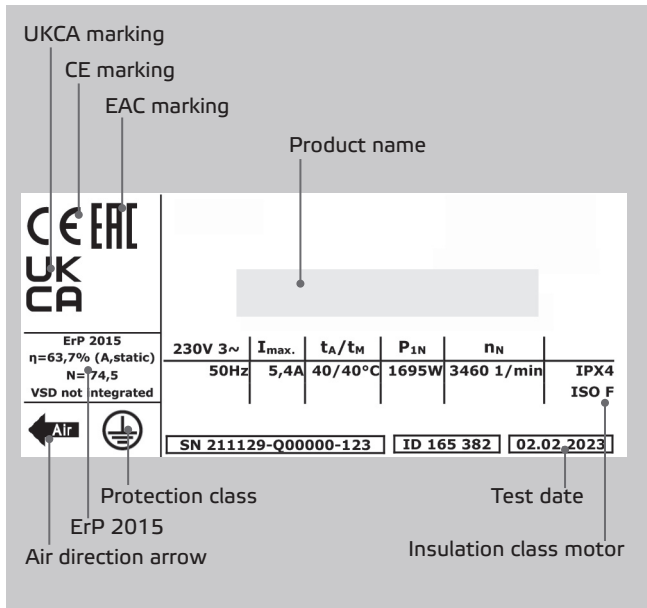

Legend:

- I_{max} Max. current consumption
- t_A / t_M Max. ambient temperature / Max. medium temperature
- P_{1N} Rated power consumption
- n_N Rated speed
- ErP Data ErP Conformity, if required according to Reg. 327/2011
- η Overall efficiency
- N Efficiency at the optimum energy efficiency
- ID Item number
- SN Serial number

6. DELIVERY CONTENTS

- 1 x roof fan with constant pressure control
- 1 x Installation, operating and maintenance instructions
- EC Declarations of conformity
- EC-Declaration of Incorporation (Directive 2006/42/EC)

7. TECHNICAL DATA

Product name	Item number	Voltage U_N V	Frequency f_N Hz	Rated power consumption P_N W	Max. motor current I_{max} A	Max. ambient temperature t_A °C	Max. medium temperature t_M °C	Sound power inlet dB(A)	Sound power outlet dB(A)	Wiring diagram	Weight kg
DHA 190 EC O CP S 01	165071	230V ~	50/60	111	1,0	50	50			130426	5,3
DHA 220 EC O CP S 01	166165	230V ~	50/60	119	1,0	60	60			130426	5,1
DHA 250 EC CP 20	129702	230V ~	50/60	204	1,7	60	60	80	85	130426	6,9
DHA 250 EC CP 21	159129	230V ~	50/60	172	1,4	60	60	73	73	125223	5,7

8. DIMENSIONS

DHA...EC CP 20 / ...EC O CP S

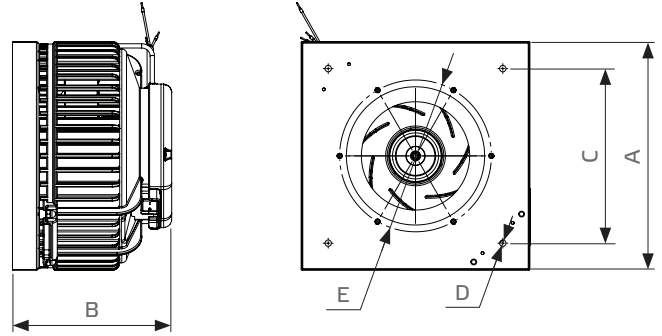

Product name	Item number	A	B	C	D	E
		mm	mm	mm	mm	mm
DHA 190 EC O CP S 01	165071	□321	223	□245	4xØ9	Ø213 6x M6x15
DHA 220 EC O CP S 01	166165	□321	223	□245	4xØ9	Ø213 6x M6x15
DHA 250 EC CP 20	129702	□321	223	□245	4xØ9	Ø213 6x M6x15
DHA 250 EC CP 21	159129	□321	223	□245	4xØ9	Ø213 6x M6x15

9. TRANSPORT AND STORAGE

Transport and storage should only be performed by specialist personnel in accordance with the assembly and operating manual and regulations in force.

The following points should be noted and followed:

- Check the delivery according to the delivery note to ensure it is complete and correct and check for any damage. Any missing quantities or damage incurred during transport should be confirmed by the carrier. No liability is accepted if this is not observed.
- For weight see technical data
- It should be transported with suitable lifting equipment in the original packaging or on the transport equipment indicated.
- If transported with a forklift, it should be ensured that the product is resting with the basic profile or base frame completely on the forks or on a pallet and the product's centre of gravity is between the forks.
- The driver must be authorized to drive a forklift.
- Do not go beneath the suspended load.
- Avoid damage or deformation of the housing.
- The product must be stored in a dry area and protected from the weather in the original packaging. Open pallets should be covered with tarpaulins. Even weatherproof modules should be covered because their weather resistance is only guaranteed after complete installation. If moisture has penetrated into the original packaging, remove it immediately.
- Storage temperature between +5 °C and +40 °C. Avoid severe temperature fluctuations.
- If the product has been in storage for more than a year, check the smooth running of impellers and valves by hand.

10. ASSEMBLY

Assembly work may only be performed by specialist personnel in accordance with the installation and operating manual and the regulations and standards in force.

The following points should be noted and followed:

- The foundation must be even and levelled. It must not exhibit unevenness or a slope in any direction.
 - Set up and align the machine with the aid of a water level. A perfect function of the device can be guaranteed only if levelled mounted.
 - Only suitable installation aids, in accordance with regulations, should be used.
 - The device must be installed in such a way that it is easily accessible for maintenance and cleaning purposes.
 - The unit should only be installed with authorized and suitable fastening materials at all fastening points.
 - Do not distort the unit when installing.
 - Just use the indicated mounting and fixing places. No holes should be made in the housing or any screws screwed into it.
 - The duct system must not be supported on the housing.
 - For structure-borne sound decoupling, a flexible connection is recommended when connected on a duct system.
 - The length of straight tube before fan must be at least 2.5 times the fan diameter
-
- The pressure measurement hose is placed in the duct to be controlled (vacuum side). Check leak tightness while installing.

1. Cover
2. Constant pressure control
3. Mounting screws
4. Roof fan
5. Connection cable
6. Pressure measurement hose
7. Roof socket (Accessories)

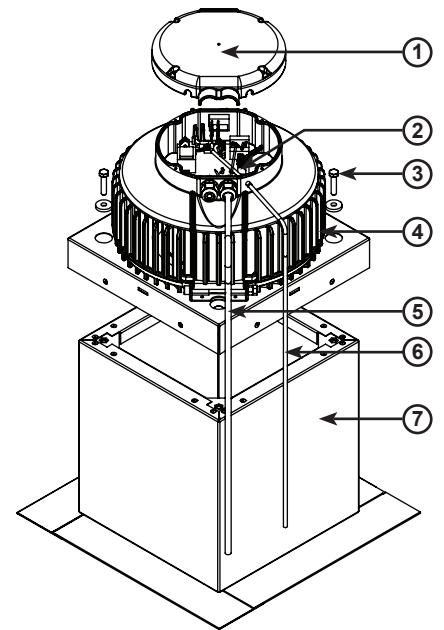

10.1. Mounting on roof socket (DSF)

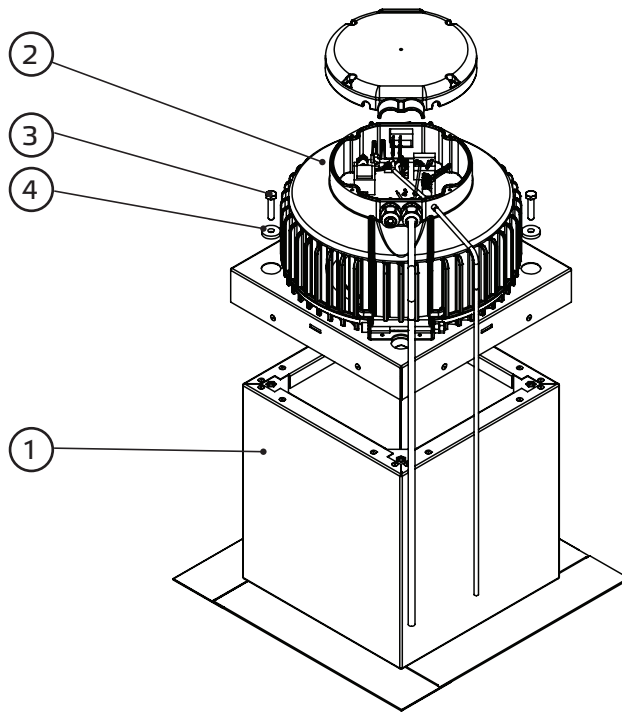

- Fasten the roof fan (2) with screws and washers (3) and (4) on the roof socket (1)

10.2. Mounting of electrical connection

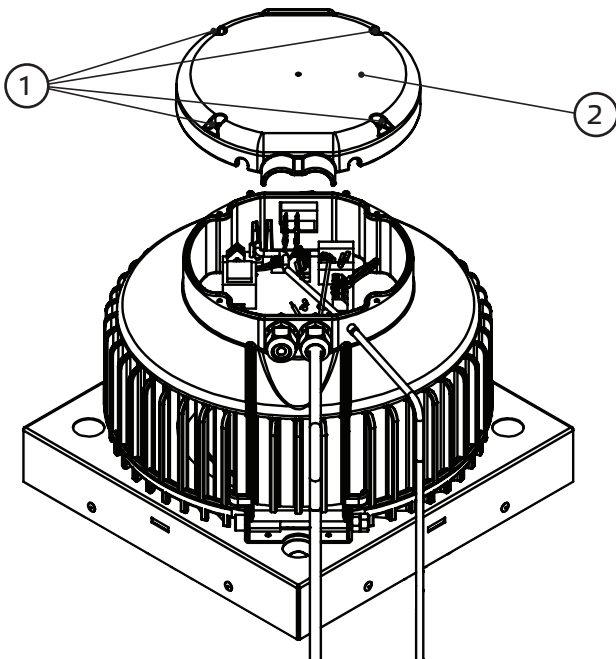

Connection power supply:

- Release screws (1)
- Remove cover (2)
- Perform the wiring according to the terminal diagram

10.3. Installation examples

DSF - Flat roof socket / Sloped roof socket

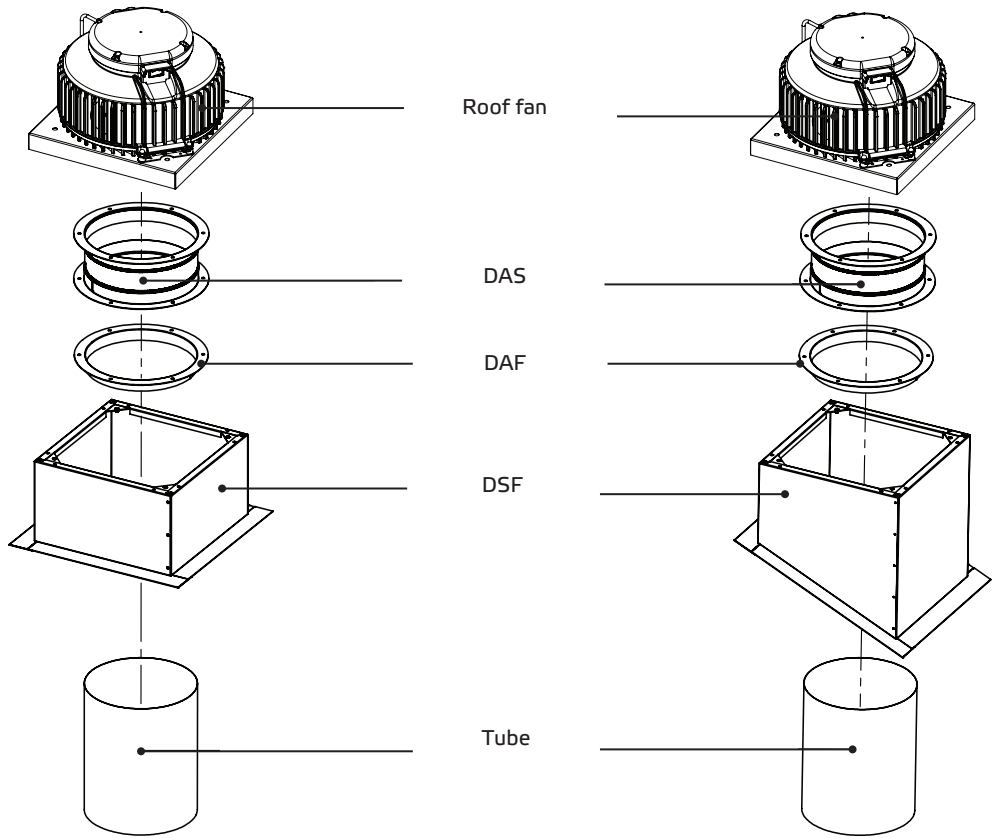

Illustrations exemplary

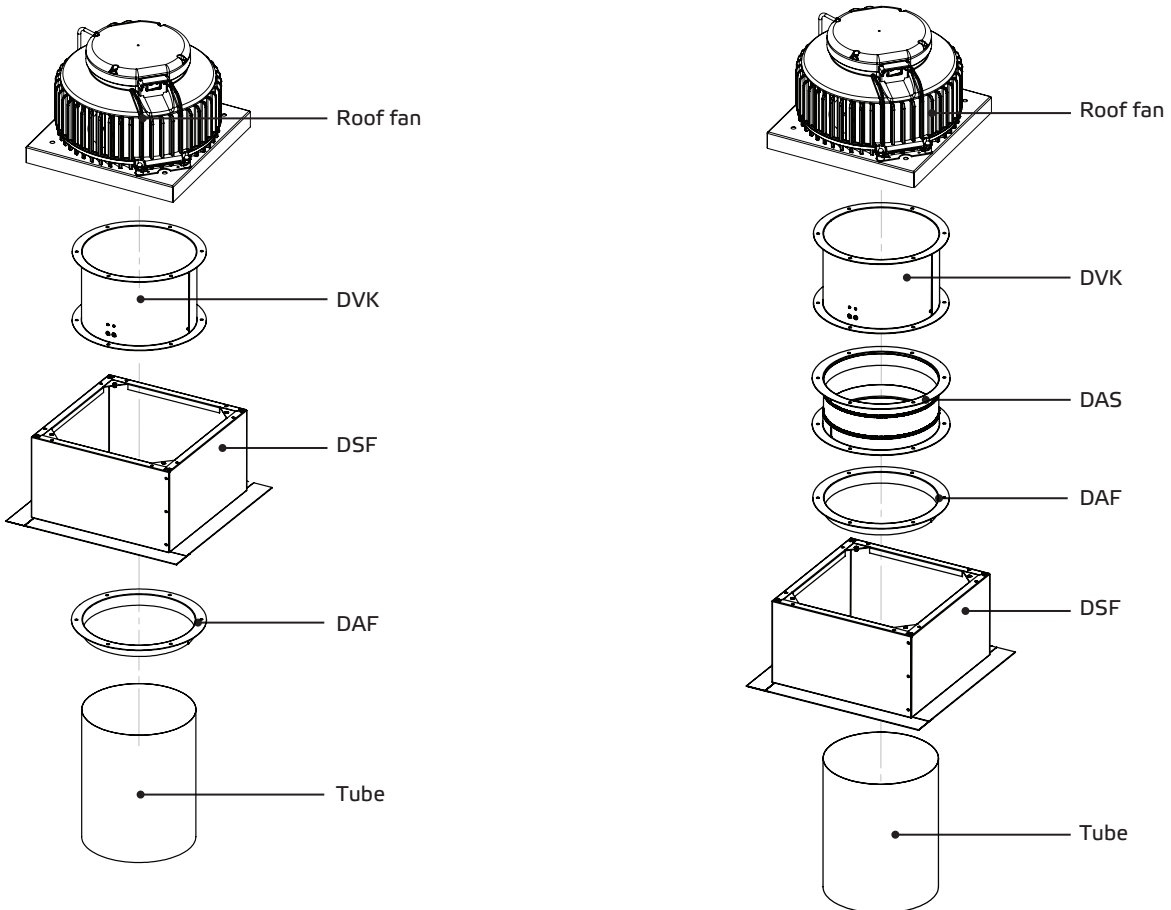

DSS - Socket silencer / Sloped roof socket silencer

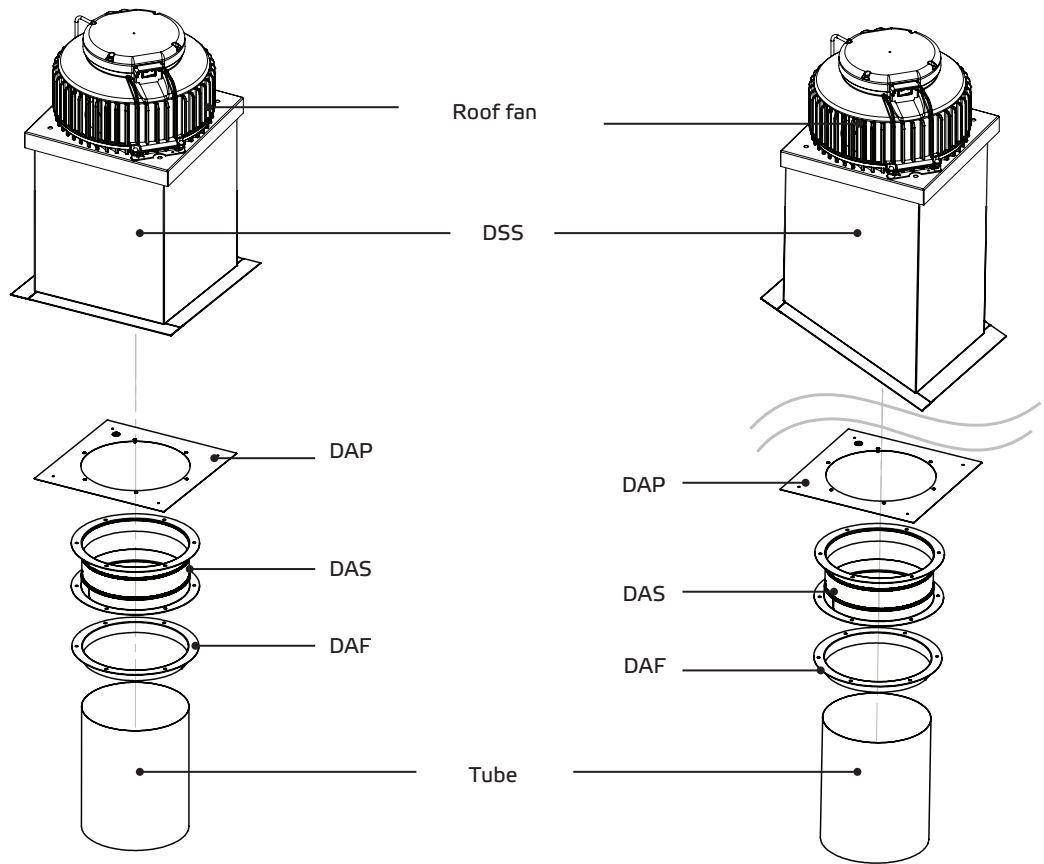

Illustrations exemplary

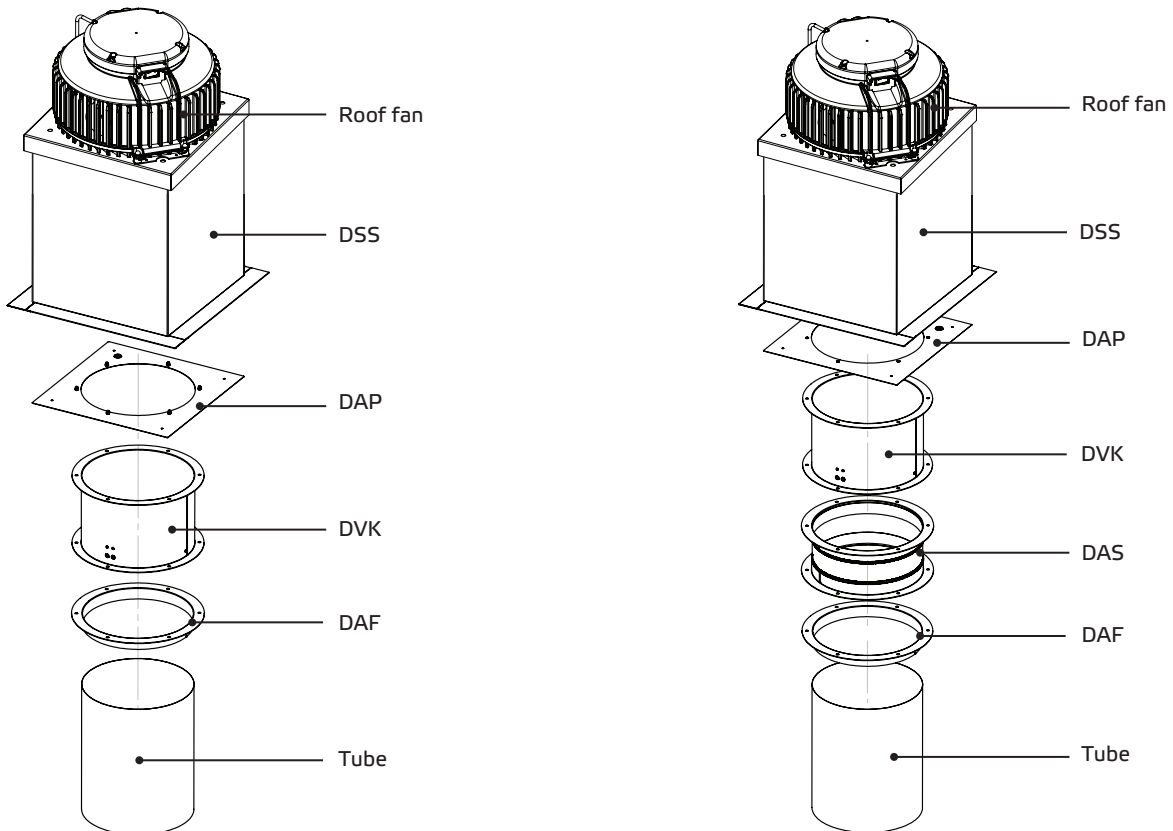

11. ELECTRICAL CONNECTION



- Electricity warning (hazardous voltage)!

» Failure to observe the hazard may result in death, injury or damage to property.

→ Before performing any work on conductive parts, always disconnect the unit completely from the electricity supply and make sure that it cannot be switched back on again.

The electrical installation may only be carried out by qualified electricians in compliance with the installation, operating and maintenance instructions and the applicable national regulations, standards and guidelines:

- ISO, DIN, EN and VDE specifications, including all safety requirements.
- Technical connection conditions.
- Safety at work and accident prevention requirements.

This list does not claim to be complete.

Requirements should be applied under one's own personal responsibility.

- The electrical connections must be made as shown in the corresponding wiring diagrams and terminal diagrams.
- The type of cable, size of cable and method of laying should be determined by an authorized electrician.
- Low and extra-low voltage cables should be laid separately.
- If no repair switch is integrated in the device, an all-pole mains disconnecting switch with min. 3 mm contact opening must be provided in the supply line.
- Use a separate cable inlet for each cable.
- Any cable inlets that are not used must be sealed so that it is airtight.
- All cable inlets must have strain relief.
- Create equipotential bonding between the unit and the duct system.
- Check all protective measures after the electrical connection work (earthing resistance, etc.)
- Motor current and motor power must not exceed the values stated on the motor nameplate. The specified max. fan speed must never be exceeded, otherwise the motor and fan will be destroyed by this overload and dissolved or flying parts can destroy other components.

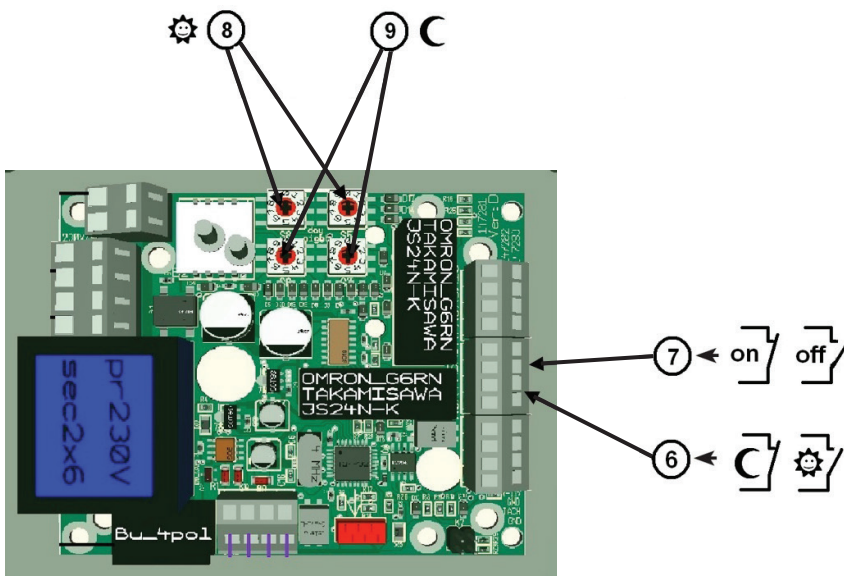

6. X3, X4 Open: day-time operation
Closed: night-time operation
7. X5, X6 Open: regulator OFF
Closed: regulator ON
8. Set-point: day 10-990 Pa
9. Set-point: night 10-990 Pa

Only potential-free contacts may be connected at terminals X3 and X4, and X5 and X6. Applying an external voltage can seriously damage the regulator.

The regulations for safety extra-low voltages must be observed.



The maximum pressure in a ventilation plant must not exceed 5000 Pa. This would result in severe damage to the regulator.

Low voltage control leads must be installed so that they are separated from mains leads.

11.1. Unit supply cable / Electrical connection / wiring diagram

Connect the mains supply cable as shown in the wiring diagram. For the dimensioning of the line, observe the unit's rating plate and the relevant guidelines. Appropriate protection with correctly dimensioned automatic safety breakers (circuit protection breaker) must be provided.

The device must be connected according to the wiring diagram. For fans which are controlled by external control devices, the corresponding operating instructions of the manufacturer must be observed.

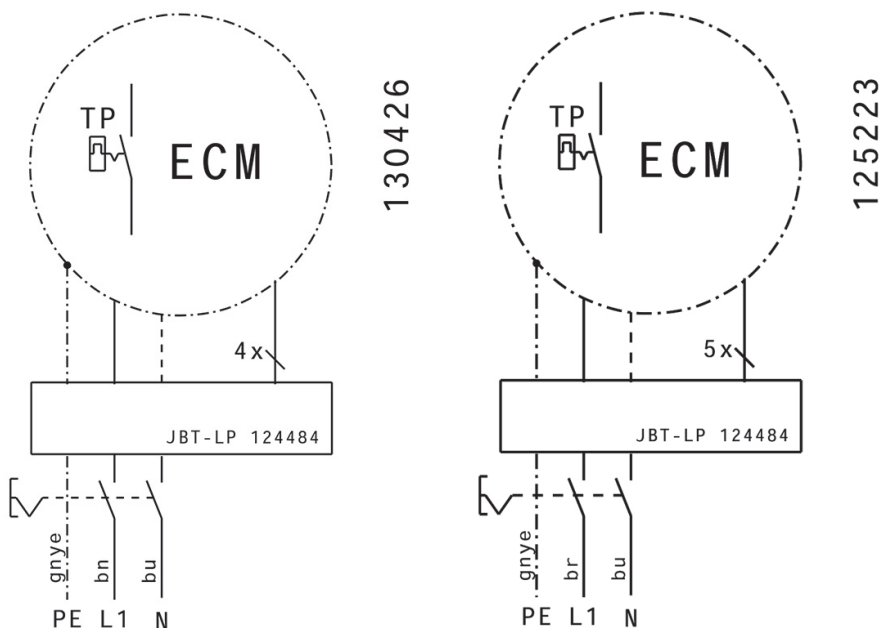

11.2. Thermal motor protection

During operation, electric motors heat up. Under certain circumstances (excessively high ambient or fluid temperatures, heavy contamination, etc.), the motor temperature may exceed the safety limit of the electrically isolated parts.

In case of EC motors an electronic temperature monitoring is present.

11.3. Fault current protection switch

If a fault current protection switch is used, only AC/DC sensitive RCD protective devices (type B or B+) are permitted.



Even when the device is switched off, voltage is applied to terminals and connections. Do not touch the device for 5 minutes after all-pole disconnection from the mains.

12. COMMISSIONING



Commissioning by trained technical personnel may only be performed after any risk has been ruled out. The following checks should be performed in accordance with the installation and operating manual and the regulations in force:

- Correctly sealed installation of the unit and duct system.
- Check the duct system, unit and medium lines, if present, remove any foreign bodies if necessary.
- The intake opening and inflow into the unit must be clear.
- Check all mechanical and electrical protection measures (e.g. earthing).
- Voltage, frequency and type of current must correspond with the rating plate.
- The pressure measuring tube will be laid in the duct.
- Setting of the desired differential pressure see 13. Operation

13. OPERATION

13.1. Operation without a control unit



CAUTION! Isolate electrical installation!

Adjust set-point

After removing the cover, you have free access to the pressure regulation circuit board.

Adjust set-point for the desired differential pressure at the two upper decade switches (8).

Switching the regulator on and off

Bridging terminals X5 and X6 switches the constant pressure regulator CON P1000 on, and removing the bridge switches it off again.

Turning the night mode ON and OFF

By bridging the terminals X3 and X4 the night mode is switched on, by removing the bridge, it is switched off.

Changing day-time set-point

Adjust set-point Day with the decade switches (8).

e.g. $\boxed{3} \boxed{2} = 32 \times 10 = 320 \text{ Pa}$

Adjusting the night-time set-point

Adjust set-point Night with the decade switches (9).

e.g. $\boxed{4} \boxed{1} = 41 \times 10 = 410 \text{ Pa}$

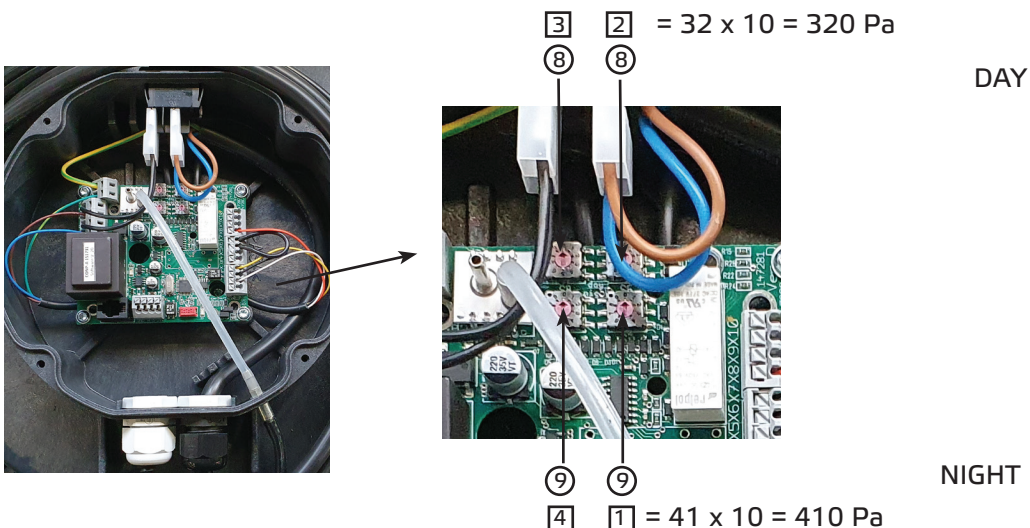

13.2. Operation with a control unit (optionally)



ATTENTION: When disconnecting the control unit from the unit after programming, the adjusted set-points will be deleted. The manually adjusted setpoints by the rotary switch will then apply.

The control unit is used for controlling and entering various functions. The display shows the various operating parameters and error messages. You can select individual menu points or change values with the various buttons.

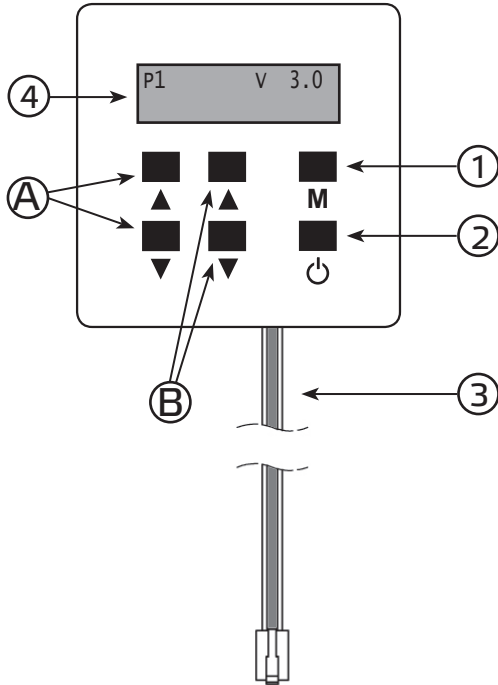

- 1) Mode Button
Switches to the control unit parameter menu.
- 2) ON/OFF Button
Button for switching the unit on or off or switching to menu management.
- A) Button A
Buttons for increasing and decreasing the set-point for "DAY"
- B) Button B
Buttons for increasing and decreasing the set-point for "NIGHT"
- 3) Control cable
- 4) Display

☀	☾	PA
150	50	0

when regulator on

OFF

when regulator off

13.2.1. Adjustment of the control unit parameter

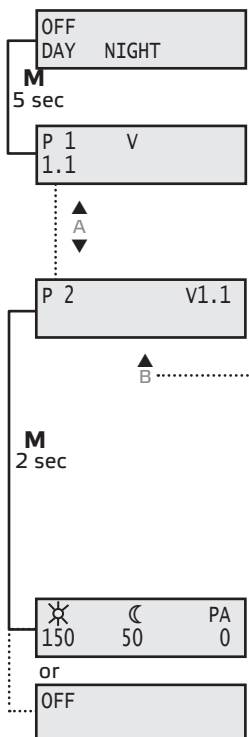

To be able to make changes to the control unit parameter, you must press the „Mode button“ (M) for at least 5 seconds. P 1 will appear on the display. Use button A (▲) to change to your desired parameter.

P 2 Language setting

Use button A (▲) to change to language setting P 2. Now press button B (▲) and the control unit will change to input mode. You can now use buttons A (▲ and ▼) to select the language required.

Press button B (▲) again to accept the language selected.

Then press the „Mode button“ (M) for at least 2 seconds. The parameters will be saved and the menu will close. The Display switches into operating mode.

when regulator on

when regulator off

Range of values	
0	DEUTSCH (Factory setting)
1	ENGLISH
2	FRANCAIS
3	DANSK
4	ESPAÑOL
5	NEDERLANDS
6	PORTUGUÊS
7	POLSKI
8	
9	

13.2.2. Menu functions

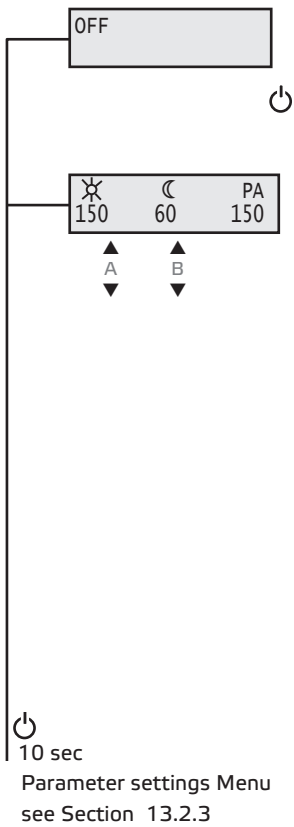

Status ON / OFF

Press the ON/OFF button (2) to switch the unit on or off. The unit's status now appears on the display with the current values.

Status display



DAY - Changing the setting

Use the A buttons on the control unit to increase (▲) or reduce (▼) the set-point.

(The setting range is limited by parameters P01 and P02.)

The DAY set-point is retained in memory after a power failure.



NIGHT - Changing the setting

Use the B buttons on the control unit to increase (▲) or reduce (▼) the set-point.

(The setting range is limited by parameters P01 and P02.)

The NIGHT set-point is retained in memory after a power failure.



Current display

Pressure difference

13.2.3. Parameter settings Menu

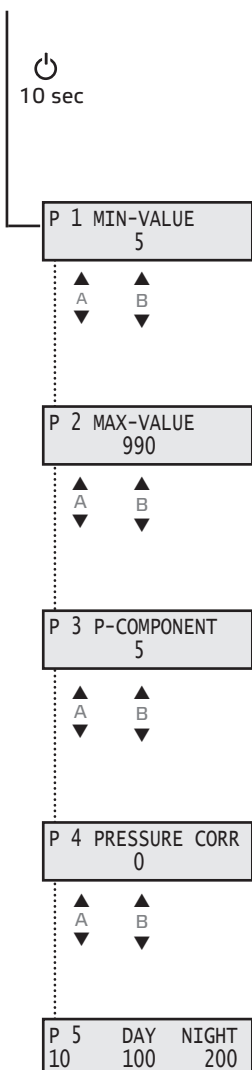

You move to the parameter settings menu menu P by pressing the ON/OFF button, which must be held down for approx. 10 seconds.

Parameter P01 is displayed on the screen. With the A (▲ and ▼) buttons on the control unit, the individual P parameters can be called up. Press the „mode button“ (M) once to return to the starting function.

P 1 Minimum set-point on control unit

Parameter for display and setting of the minimum set-point.

The setting range is from 10 Pa to 500 Pa.

The parameters can be changed with the buttons B (▲ and ▼).

P 2 Maximum set-point on control unit

Parameter for display and setting of the maximum set-point.

The setting range is from 100 Pa to 990 Pa.

The parameters can be changed with the buttons B (▲ and ▼).

P 3 P - component

The setting range is from 5 to 15.

05 = no gain 10 = average gain 15 = high gain

The parameters can be changed with the buttons B (▲ and ▼).

The works setting is 5.

The regulation tends to pulsate at high gain.

P 4 Pressure correction

The works setting is "0".

The parameters can be changed with the buttons B (▲ and ▼).

Settings between -20 Pa and +20 Pa are possible.

P 5

Control of the decade switches for Day and Night.

The current program version is listed below „P05“.

13.3. Operation with Modbus communication interface

13.3.1. Wiring diagram

To activate Modbus operation, jumper J2 must be set as shown in the following figure.

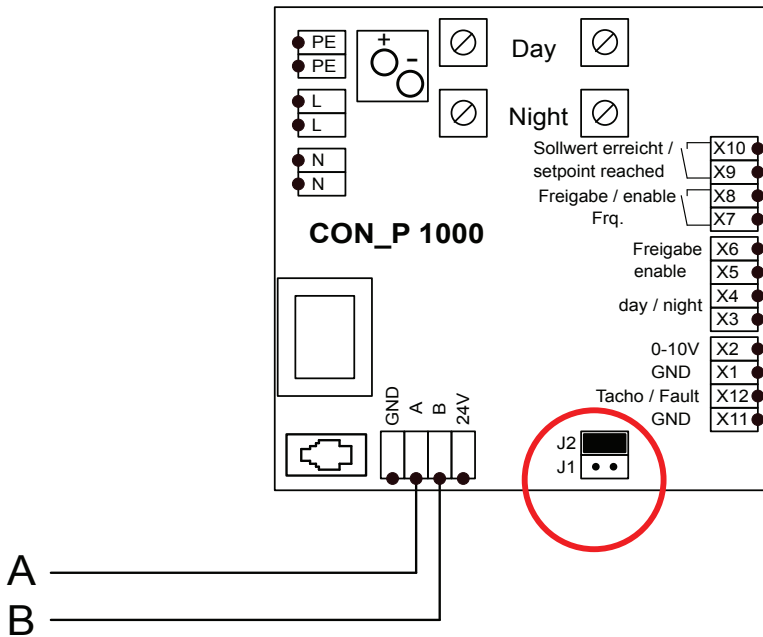

13.3.2. Interface information

The device works as a Modbus RTU slave. The interface configuration is 8N1, 9600Baud, slave address 1. The address and the baud rate can be set, see the following figure. As bus line is recommended a twisted pair data cable with 120 Ohm impedance.

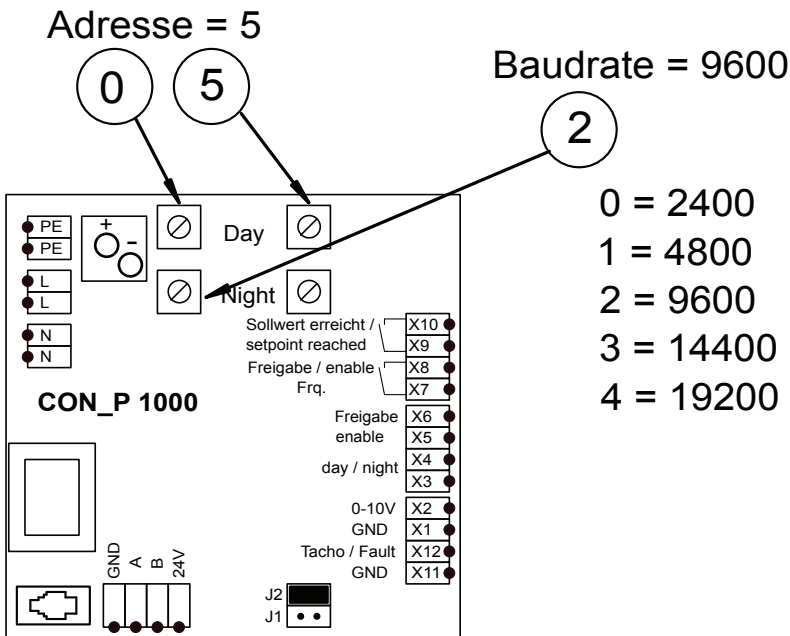

13.3.3. Functions implemented

Function code	Name	Description
03 Hex	Read Hold Register	Read device parameter
04 Hex	Read Input Register	Read current value
06 Hex	Write Single Register	Write device parameter word by word
10 Hex	Write Multiple Register	Write several device parameters word by word

Function code	Name	Sub-function	Description
08 Hex	Return Query Dat	00	Send the received message back
08 Hex	Restart Communications	01	Restart communication
08 Hex	Force Listen Only Mode	04	Switch to listen-only mode

13.3.4. Parameter table

Register address	Protocol address	Parameter name	Value range	Data type	Authority
40001	0	Reserved		integer	R/W
40002	1	Min. set-point value	10 - 500 PA	integer	R/W
40003	2	Max. set-point value	100 - 999 PA	integer	R/W
40004	3	P - component	5 - 15	integer	R/W
40005	4	Pressure correction	-20 - 20 PA	integer	R/W
40006	5	Reserved		integer	R/W
40007	6	Reserved		integer	R/W
40008	7	Reserved		integer	R/W
40009	8	Reserved		integer	R/W
40010	9	Reserved		integer	R/W
40011	10	Set-point: day	Pressure (PA)	integer	R/W
40012	11	Set-point: night	Pressure (PA)	integer	R/W
40013	12	day/night switching	0 = Day-time operation 1 = Night-time operation	integer	R/W
40034	33	Status and control word	See Table below	integer	R/W
40036	35	Save parameters	12439 Value change after saving under 0	integer	R/W

	Function	Authority	Comment
Bit 0	1 = Error present	R	integer
Bit 1	Reserved	R/W	
Bit 2	Reserved	R/W	
Bit 3	Reserved	R/W	
Bit 4	Reserved	R/W	
Bit 5	1 = Cancel error	R/W	With rising slope, error is cancelled
Bit 6	0 = Unit switched ON 1 = Unit switched OFF	R/W	shut-off with increasing flank
Bit 7	0 = Unit switched ON 1 = Unit switched OFF	R/W	With rising slope, unit switched ON
Bit 8	Reserved	R/W	
Bit 9	Reserved	R/W	
Bit 10	Reserved	R/W	
Bit 11	Reserved	R/W	
Bit 12	Reserved	R/W	
Bit 13	Reserved	R/W	
Bit 14	Reserved	R/W	
Bit 15	Reserved	R/W	

Example for switching on and off:

To switch on, 128 (decimal) must be written into register 33 (status and control word).

To switch off, 64 (decimal) must be written into register 33 (status and control word).

13.3.5. Current value table

Register address	Protocol address	Parameter name	Value range	Data type	Authority
30001	0	Reserved		integer	R/W
30002	1	Room temperature		integer	R/W
30003	2	Measured pressure	Pressure (PA)	integer	R/W
30004	3	Set day internal switch	Pressure (PA)	integer	R/W
30005	4	Set night internal switch	Pressure (PA)	integer	R/W
30006	5	Reserved		integer	R/W
30007	6	Reserved		integer	R/W
30008	7	Reserved		integer	R/W
30009	8	Reserved		integer	R/W
30010	9	Reserved		integer	R/W
30011	10	Reserved		integer	R/W
30012	11	Control fan	0 - 100 %	integer	R/W
30013	12	Pressure in range	0 = Pressure difference between setpoint and measured > 20 Pa 1 = Pressure difference between setpoint and measured < 20 Pa	integer	R/W
30014	13	Set pressure	Pressure (PA)	integer	R/W
30025	24	Error number	See Table below	integer	R/W

Current value table, protocol addresses 24 (error numbers)

Value	
0	Reserved
1	Reserved
2	Reserved
3	Reserved
4	Reserved
5	Reserved
6	Reserved
7	Reserved
8	Reserved
9	Reserved
10	Fan defective
11	Reserved
12	Reserved
13	Reserved
14	Reserved
15	Reserved
16	Reserved
17	Reserved
18	Reserved
19	Reserved
20	Reserved

14. MAINTENANCE AND CLEANING



Servicing, troubleshooting and cleaning may only be performed by specialised personnel in accordance with this installation and operating manual and the regulations in force.



- Make sure that no connections or components are loosened unless the device is disconnected from the mains. Make sure that the equipment cannot be switched back on again.



- Individual components must not be interchanged. For example, the components intended for one product may not be used for other products.



- The regular maintenance and care of our devices is designed to ensure proper function, value retention and avoidance of damage. Keep a maintenance log.

- Perform the specified maintenance on the unit at the specified intervals.

Our devices require little maintenance when operated properly.

The following work should be performed at regular intervals, in accordance with health and safety regulations:

- Check the operation of the control system and safety devices.
- Check electrical connections and wiring for damage.
- Remove any dirt from the fan impeller or impellers and from inside the fan housing in order to prevent any unbalance or reduction in output.
 - Do not use aggressive or easily flammable products for cleaning (impellers/housing).
 - Preferably only water (not flowing water) or mild soapsuds should be used.
 - The impeller should be cleaned with a cloth or brush.
 - Never use a high-pressure cleaner.
 - Balancing clips must not be moved or removed.
 - The impeller and fittings must not be damaged in any way.
- Pressure fittings and hoses should be checked regularly for impurities and, if necessary, they should be cleaned, respectively the pressure hoses should be replaced.

Before putting the unit back into operation after maintenance and servicing work, carry out a visual inspection as described in section 11. and 12.

14.1. Checklist Maintenance and Service

Description	check interval
Triggering device	monthly
■ Fan	
Check fan for function and operational readiness (test run at least 15 minutes)	every 6 months
Check fan for function and operational readiness (test run at least 1 hour)	yearly
Check for dirt, damage, corrosion and fastening	every 6 months
Function-preserving cleaning	every 6 months
Check impeller rotation direction	yearly
Check flexible connections for leaks	yearly
Check impeller for imbalance	yearly
Check protective device for function	yearly
■ Motor	
Check externally for dirt, damage, corrosion and fastening	every 6 months
Function-preserving cleaning	yearly
Check bearing for noise	yearly
Check terminals for tight fit	yearly
Measure the voltage	yearly

15. LIFETIME AND DISPOSAL

15.1. Product life

The motors are equipped with maintenance-free, permanently lubricated ball bearings. Under normal operating conditions, the expected lifetime is about 30,000 operating hours.

The information given here depends strongly on the respective field of application as well as the environmental conditions. We recommend replacing these fans after reaching about 30,000 operating hours or 5 years.

15.2. Decommissioning and disposal



When disassembling, parts under voltage are exposed, which can lead to electric shock when touched. Before dismantling, disconnect the fan from all poles of the mains and secure against being switched on again!

Parts and components of the device that have reached their lifetime, e.g. due to wear, corrosion, mechanical stress, fatigue and/or all other, not directly recognizable effects, must be disposed of professionally and properly after disassembly in accordance with national and international laws and regulations. The same applies to excipients in use such as oils and fats or other substances. The conscious or unconscious reuse of used components such as e.g. impellers, rolling bearings, motors, etc. can lead to a risk to persons, the environment as well as machinery and equipment. The applicable local operating regulations must be observed and applied.

15.3. Spare parts (motor + impeller)

Only original spare parts may be used.

The repair may only be carried out by personnel trained and authorized.

16. TROUBLESHOOTING

Further faults may occur before and during operation of the unit which are not indicated by an error message on the display.

If the fan stops due to a malfunction, please disconnect all poles of the fan from the power supply.

Please then check whether there is an obvious fault (blocked impeller, damage, etc.) and rectify it. If there are no obvious faults, you can reconnect the fan to the mains after waiting for approx. 1 minute.

If there is still no function, please proceed according to the following table:

Fault	Possible cause	Remedy methods
<ul style="list-style-type: none"> ■ Fan does not start 	<ul style="list-style-type: none"> ■ No power supply ■ Impeller does not rotate freely ■ Set-point value differential pressure is set to 0 Pa. ■ Supply lead not connected. ■ The regulator is not switched on. 	<ul style="list-style-type: none"> ■ Check mains supply / connections ■ Find out the causes and, if possible, remove the fault. If not possible, contact the supplier. ■ Adjust set-point value differential pressure. ■ Have electrical power supply connected by an authorised electrician. ■ Switch on regulator. - With remote control (optional) - with a contact between X5 and X6
<ul style="list-style-type: none"> ■ Motor overheated / temperature protection is triggered 	<ul style="list-style-type: none"> ■ Fault of the ball bearings ■ Too high operating temperature ■ Air flow is too low, motor cannot cool down 	<ul style="list-style-type: none"> ■ Contact the supplier ■ Observe the data on the nameplate ■ See fault „Low air flow“
<ul style="list-style-type: none"> ■ Device too noisy / casing vibrations 	<ul style="list-style-type: none"> ■ Dirt deposits on the impeller ■ Imbalance of the impeller ■ Connection with intake or exhaust pipe / duct causes vibrations / oscillations ■ Fixing screws released ■ Fault of the ball bearings ■ Loose impeller blade 	<ul style="list-style-type: none"> ■ See chapter maintenance and cleaning ■ Contact the supplier ■ Install fan with vibration dampers ■ Tighten screws ■ Contact the supplier ■ Contact the supplier
<ul style="list-style-type: none"> ■ Low airflow 	<ul style="list-style-type: none"> ■ Impeller runs in the wrong direction (wrong air transport direction) ■ High pressure losses in the system ■ Return flaps closed or only partially open ■ Duct system clogged ■ Speed control incorrectly set / incorrectly connected 	<ul style="list-style-type: none"> ■ Note the marking on the device / nameplate. Check electrical connections ■ Improve piping configuration or select a more powerful fan ■ Check drive system / installation position of the return flap ■ Remove blockage / clean protective grille ■ Check settings / switching unit and possibly adjust / connect
<ul style="list-style-type: none"> ■ No regulation! 	<ul style="list-style-type: none"> ■ Pressure measured in the wrong place 	<ul style="list-style-type: none"> ■ Connect the longer pressure measurement hose to a suitable point in the ventilation duct
<ul style="list-style-type: none"> ■ No ModBus communication 	<ul style="list-style-type: none"> ■ Jumper J2 is set to control unit 	<ul style="list-style-type: none"> ■ Set jumper J2 to ModBus
<ul style="list-style-type: none"> ■ Remote control unit shows ERR 	<ul style="list-style-type: none"> ■ Jumper J2 is set to ModBus 	<ul style="list-style-type: none"> ■ Set jumper J2 to control unit
<ul style="list-style-type: none"> ■ Jumper J1 set to tacho signal Fan does not run and green LED D23 flashes quickly <div style="border: 1px solid black; padding: 2px; width: fit-content;">F10 FAULT FAN</div>	<ul style="list-style-type: none"> ■ Motor has a fault relay ■ Error input not connected ■ Bridge in fault input ■ Motor defective 	<ul style="list-style-type: none"> ■ Set jumper J1 to the error relay ■ Set jumper J1 to the error relay and connect a bridge to the error input ■ Set jumper J1 to the error relay ■ Contact service
<ul style="list-style-type: none"> ■ Jumper J1 set to tacho signal Fan does not run and green LED D23 flashes quickly <div style="border: 1px solid black; padding: 2px; width: fit-content;">F10 FAULT FAN</div>	<ul style="list-style-type: none"> ■ Motor has a tachometer signal ■ Error input not connected ■ Motor defective 	<ul style="list-style-type: none"> ■ Set jumper J1 to tacho signal ■ Connect a bridge to the error input ■ Contact service



ruck Ventilatoren GmbH

Max-Planck-Str. 5

D-97944 Boxberg-Windischbuch

Tel. +49 7930 9211-300

Fax +49 7930 9211-166

info@ruck.eu

www.ruck.eu

Information updated

print 08.03.2023

mdar_pb_17d_k10001_en

We reserve the right to make changes

Language:

English