



data ventilátoru

21. 4. 2020

verze FANselect V 1.01 (200311), AMCA V 1.03 February, 2019 / 1.20.03.11 | 541 |



typ

FN030-4IL.ZC.A5P4

artiklové č.

178114 | Portfolio STD-WW

technická data

motor	-	ECblue
napájení	-	1~ 230V 50Hz
maximální okolní teplota (t _r)	°C	50
účinnost η_{statA}	%	44
účinnost N_{actual} N_{SOLL}		55,7 40
ErP - třída		2015 EC regulátor integrovaný
grille influence		pressure side measured

data ventilátoru

otáčky ventilátoru (n) max. (n _{max})	1/min	- 2370
frekvence v prac.bodě (f _{DP}) (f _{max})	Hz	50 60
hmotnost výrobku (m _{Pr})	kg	2.6
zástavbové rozměry zohledněny (Š x V x H)	mm	1870 x 1230 x 2000

PF:PF_50; Ano:178114; STol:±10 %





charakteristika / hlučnost

21. 4. 2020

verze FANselect V 1.01 (200311), AMCA V 1.03 February, 2019 / 1.20.03.11 | 541 |

1 FN030-4IL.ZC.A5P4
178114 | Portfolio STD-WW

Measured in full nozzle with pressure side guard grille in air flow direction V in installation type A according to ISO5801
měřená hustota 1.16 [kg/m³]

vzduchový výkon p_{sF}

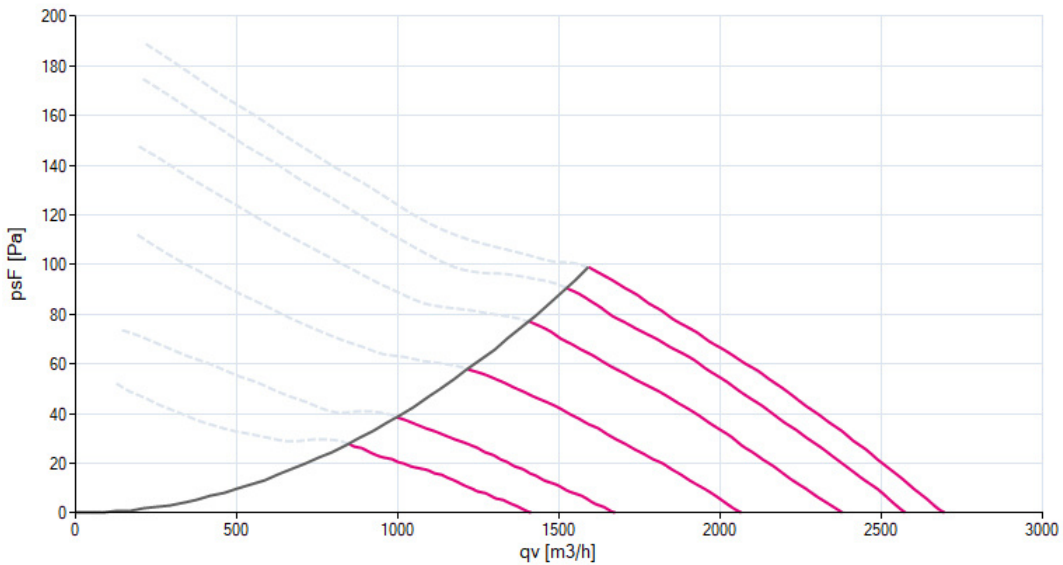

hlučnost ($L_{w(A),5}$)

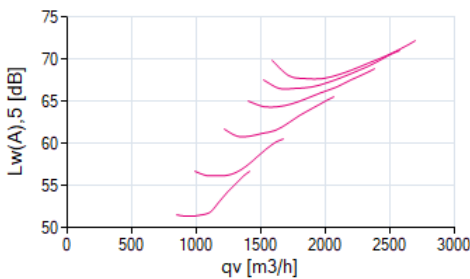

hlučnost ($L_{w(A),6}$)

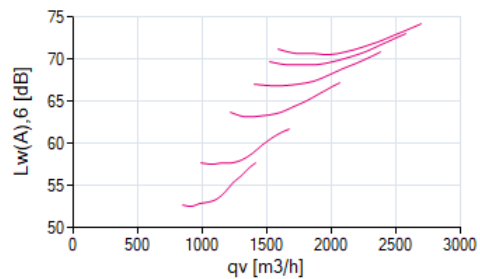

1 FN030-4IL.ZC.A5P4

f [Hz]	sum	63	125	250	500	1000	2000	4000	8000	f [Hz]	sum	63	125	250	500	1000	2000	4000	8000	
$L_{w(A),5}$		-	-	-	-	-	-	-	-	$L_{w(A),6}$		-	-	-	-	-	-	-	-	-
$L_{w,5}$		-	-	-	-	-	-	-	-	$L_{w,6}$		-	-	-	-	-	-	-	-	-



účinnost / příkon

21. 4. 2020

verze FANselect V 1.01 (200311), AMCA V 1.03 February, 2019 / 1.20.03.11 | 541 |

1 FN030-4IL.ZC.A5P4
178114 | Portfolio STD-WW

Measured in full nozzle with pressure side guard grille in air flow direction V in installation type A according to ISO5801
měřená hustota 1.16 [kg/m³]

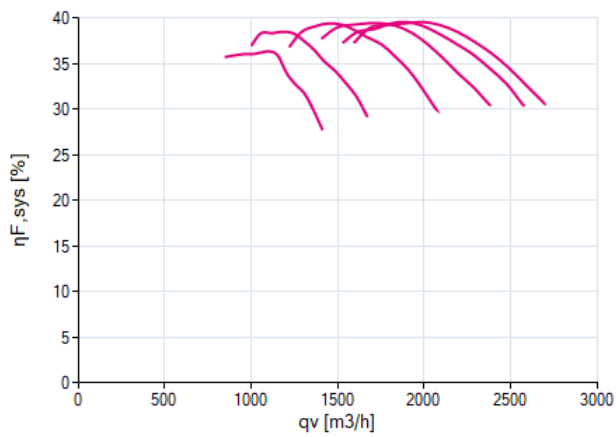
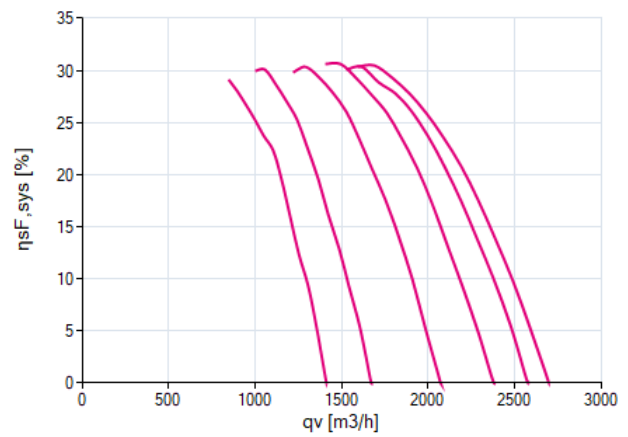
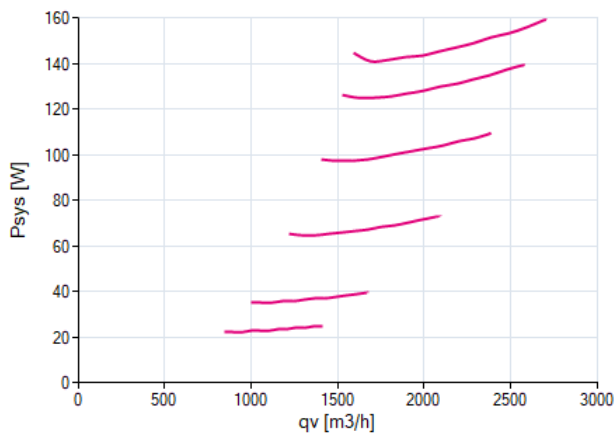
účinnost $\eta_{F,sys}$ účinnost $\eta_{sF,sys}$ příkon P_{sys} 



nominální hodnoty

21. 4. 2020

verze FANselect V 1.01 (200311), AMCA V 1.03 February, 2019 / 1.20.03.11 | 541 |

1



FN030-4IL.ZC.A5P4
178114

1" 200-240V 50Hz P1 0.17kW
1.70-1.40A 2370/MIN 50°C
1" 200-240V 60Hz P1 0.17kW
1.70-1.40A 2370/MIN 50°C
IP54 THCL155

výkres

21. 4. 2020

verze FANselect V 1.01 (200311), AMCA V 1.03 February, 2019 / 1.20.03.11 | 541 |

1



FN030-4IL.ZC.A5P4
178114



schéma zapojení

21. 4. 2020

verze FANselect V 1.01 (200311), AMCA V 1.03 February, 2019 / 1.20.03.11 | 541 |

1

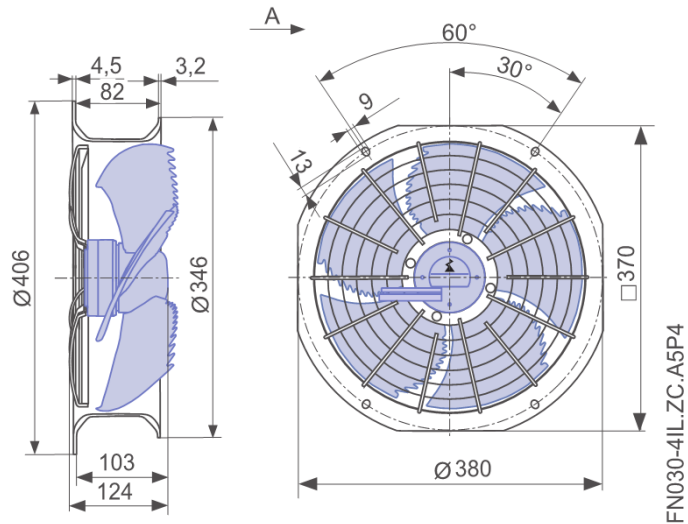

FN030-4IL.ZC.A5P4
178114

