



data ventilátoru

21. 4. 2020

verze FANselect V 1.01 (200311), AMCA V 1.03 February, 2019 / 1.20.03.11 | 541 |



typ

FN035-4IL.ZC.A5P5

artiklové č.

178122 | Portfolio STD-WW

technická data

| | | |
|--|----|--------------------------|
| motor | | ECblue |
| napájení | - | 1~ 230V 50Hz |
| maximální okolní teplota (t _a) | °C | 40 |
| ErP - třída | | < 125W |
| grille influence | | pressure side measured |

data ventilátoru

| | | |
|--|-------|--------------------|
| otáčky ventilátoru (n) max. (n _{max}) | 1/min | - 1660 |
| frekvence v prac.bodě (f _{DP}) (f _{max}) | Hz | 50 60 |
| hmotnost výrobku (m _{Pr}) | kg | 2.9 |
| zástavbové rozměry zohledněny (Š x V x H) | mm | 1870 x 1230 x 2000 |

PF:PF_50; Ano:178122; STol:+-10 %



charakteristika / hlučnost

21. 4. 2020

verze FANselect V 1.01 (200311), AMCA V 1.03 February, 2019 / 1.20.03.11 | 541 |

1 FN035-4IL.ZC.A5P5
178122 | Portfolio STD-WW

Measured in full nozzle with pressure side guard grille in air flow direction V in installation type A according to ISO5801
měřená hustota 1.16 [kg/m³]

vzduchový výkon p_{sF}

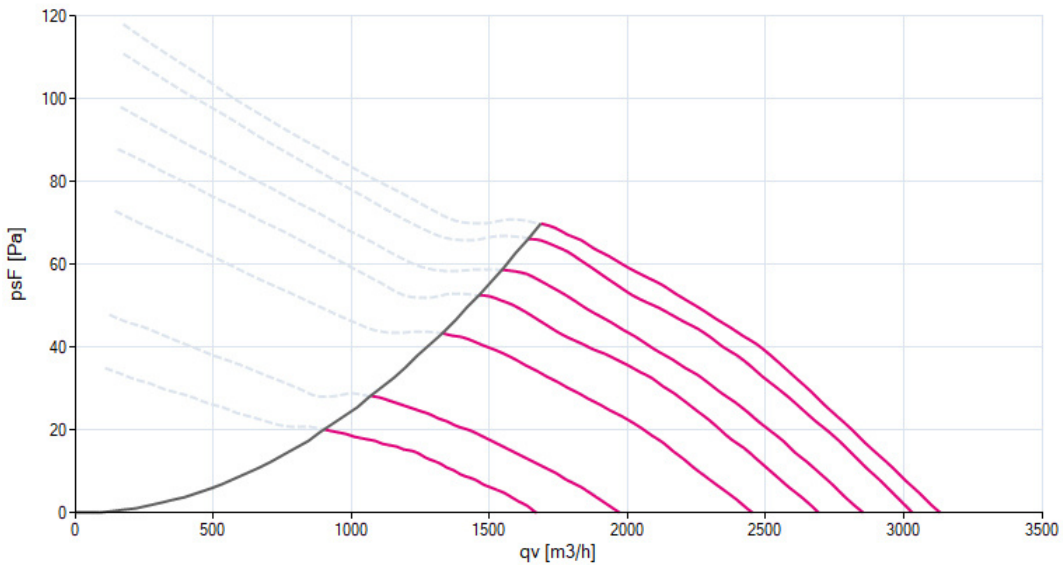

hlučnost ($L_{w(A),5}$)

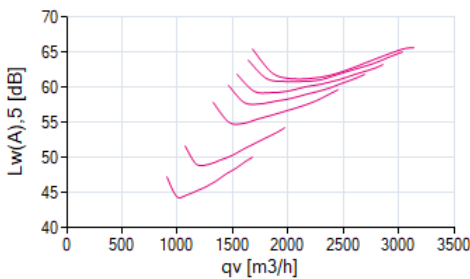

hlučnost ($L_{w(A),6}$)

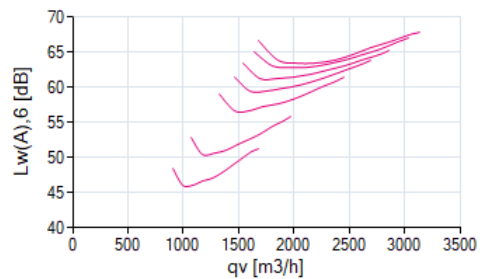

1 FN035-4IL.ZC.A5P5

| f [Hz] | sum | 63 | 125 | 250 | 500 | 1000 | 2000 | 4000 | 8000 | f [Hz] | sum | 63 | 125 | 250 | 500 | 1000 | 2000 | 4000 | 8000 |
|--------------|-----|----|-----|-----|-----|------|------|------|------|--------------|-----|----|-----|-----|-----|------|------|------|------|
| $L_{w(A),5}$ | - | - | - | - | - | - | - | - | - | $L_{w(A),6}$ | - | - | - | - | - | - | - | - | - |
| $L_{w,5}$ | - | - | - | - | - | - | - | - | - | $L_{w,6}$ | - | - | - | - | - | - | - | - | - |



účinnost / příkon

21. 4. 2020

verze FANselect V 1.01 (200311), AMCA V 1.03 February, 2019 / 1.20.03.11 | 541 |

1 FN035-4IL.ZC.A5P5
178122 | Portfolio STD-WW

Measured in full nozzle with pressure side guard grille in air flow direction V in installation type A according to ISO5801
měřená hustota 1.16 [kg/m³]

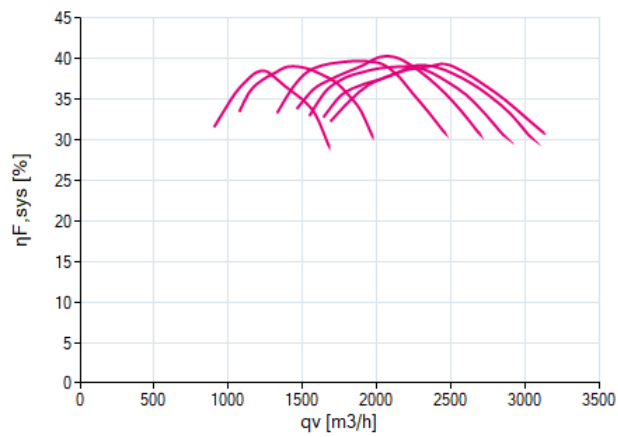
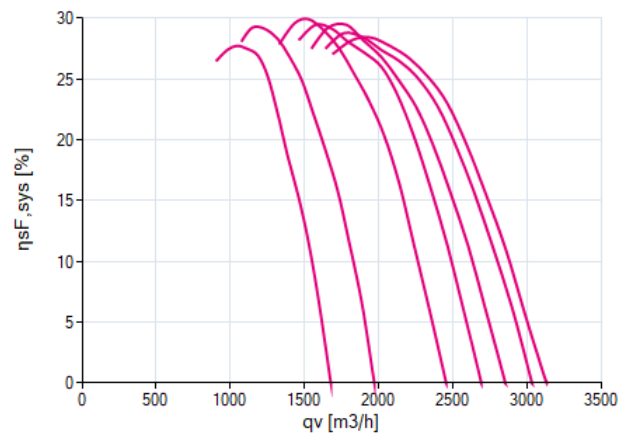
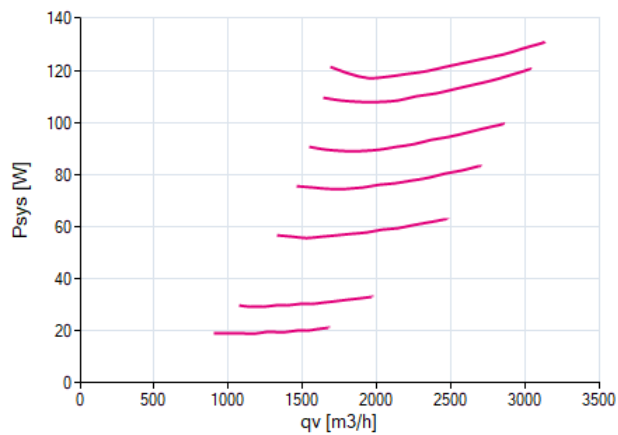
účinnost $\eta_{F,sys}$ účinnost $\eta_{sF,sys}$ příkon P_{sys} 



nominální hodnoty

21. 4. 2020

verze FANselect V 1.01 (200311), AMCA V 1.03 February, 2019 / 1.20.03.11 | 541 |

1



FN035-4IL.ZC.A5P5
178122

1~ 200-240V 50Hz P1 0.14kW
1.45-1.20A 1660/MIN 40°C
1~ 200-240V 60Hz P1 0.14kW
1.45-1.20A 1660/MIN 40°C
IP54 THCL155

výkres

21. 4. 2020

verze FANselect V 1.01 (200311), AMCA V 1.03 February, 2019 / 1.20.03.11 | 541 |

1



FN035-4IL.ZC.A5P5
178122



schéma zapojení

21. 4. 2020

verze FANselect V 1.01 (200311), AMCA V 1.03 February, 2019 / 1.20.03.11 | 541 |

1

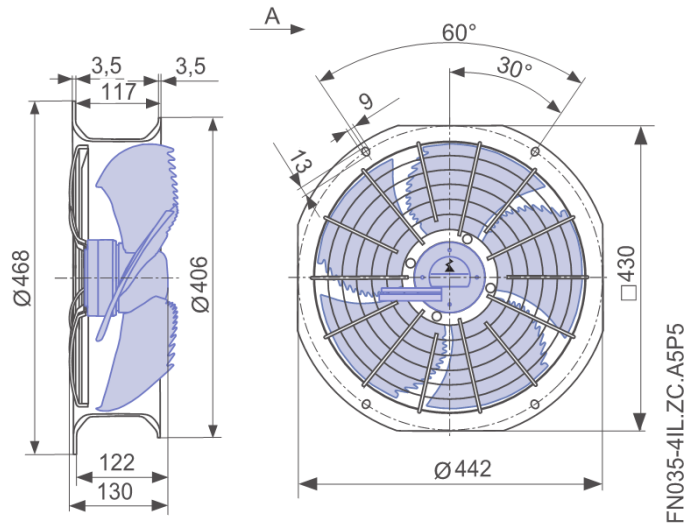

FN035-4IL.ZC.A5P5
178122

