



School Ventilation Solutions





**Air
is our most
important
food**



Fresh air

Healthy indoor microclimate is vital for our children and students in every educational institution. Fresh air prevents diseases and is essential for brain function. Poor ventilation in classrooms affect ability to concentrate and performance of the students. Therefore, the importance of fresh air could not be stressed enough. Modern people are lacking fresh air – we spend most of our time indoors, so the quality of the air inside is extremely important. Air recirculating indoor air purifiers do not supply fresh air and therefore does not affect carbon dioxide (CO₂) levels. Such devices reduce spread of infectious diseases by filtering recirculated indoor air; however, this is not enough for proper ventilation.

CO₂ concentration

One of the most important and easily measurable indoor air quality parameters is carbon dioxide (CO₂) concentration. CO₂ concentration in poorly ventilated classes continues to rise during the day, therefore, in order to ensure air quality, constant monitoring and control of CO₂ concentration is required.

Mechanical ventilation

Scientific research (prof. Achim Trogisch, HTW Dresden) shows that a sufficient amount of fresh air (sufficient air circulation) can reduce CO₂ levels, as well as the concentration of microorganisms and solid particles in indoor air. Ventilation through slightly open windows is only a partially helpful solution, as drafts should be created to ensure fresh air circulation. This ventilation solution also brings in dusts, harmful particles and odours, and in the

cold and wet seasons, it also can contribute to illnesses due to low temperatures. It also causes huge heat losses and violates hygiene norms for indoor microclimate. Therefore, adequate air quality control should be an important criterion when choosing indoor ventilation solutions – you must be able to monitor and control temperature, air circulation and carbon dioxide concentration, while taking energy efficiency into account.

We offer you a mechanical ventilation system with a heat exchanger and integrated automation, which will ensure constant supply of fresh air, low energy consumption, adequate air quality and comfort in your school.

KOMFOVENT mechanical ventilation systems with heat exchange (heat and cool recovery):

- Sustainable and energy efficient solution.
- Controlled circulation of fresh air in school premises and classrooms.
- Continuously monitors and maintains air quality parameters.

	Ventilation with heat recovery	Natural ventilation
Fresh air supply	✓	✓
CO ₂ control	✓	✗
Air filtering	✓	✗
Heat exchange	✓	✗
Humidity control	✓	✗
Temperature control	✓	✗

Indoor air quality classification: EN 13779

Room air quality	CO ₂ concentration indoors (ppm)	Fresh air volume [m ³ /h / per person]
High indoor air quality IDA 1	< 800	> 54
Medium indoor air quality IDA 2	800...1000	36...54
Moderate indoor air quality IDA 3	1000...1400	22...36
Low indoor air quality IDA 4	> 1400	< 22

Resources: VDI 6040, DIN EN 15251, VDI 2081.



Benefits of mechanical ventilation



- ✓ On demand ventilation in your classroom and school premises.
- ✓ Easy and quick installation.
- ✓ Helps to avoid excessive CO₂ levels.
- ✓ No noise from the outside (traffic, etc.).
- ✓ Significant improvement in air quality.
- ✓ Air filtration reduces concentration of microbes.
- ✓ Maximum energy savings.
- ✓ Humidity recovery – retains humidity indoors and protects the mucous membranes.
- ✓ Optimal indoor temperature – no drafts and mixing air in the air distribution system.
- ✓ Better health and higher productivity.
- ✓ Low maintenance and servicing costs due to remote diagnostics.

Ventilation solutions from KOMFOVENT

for new construction and renovation

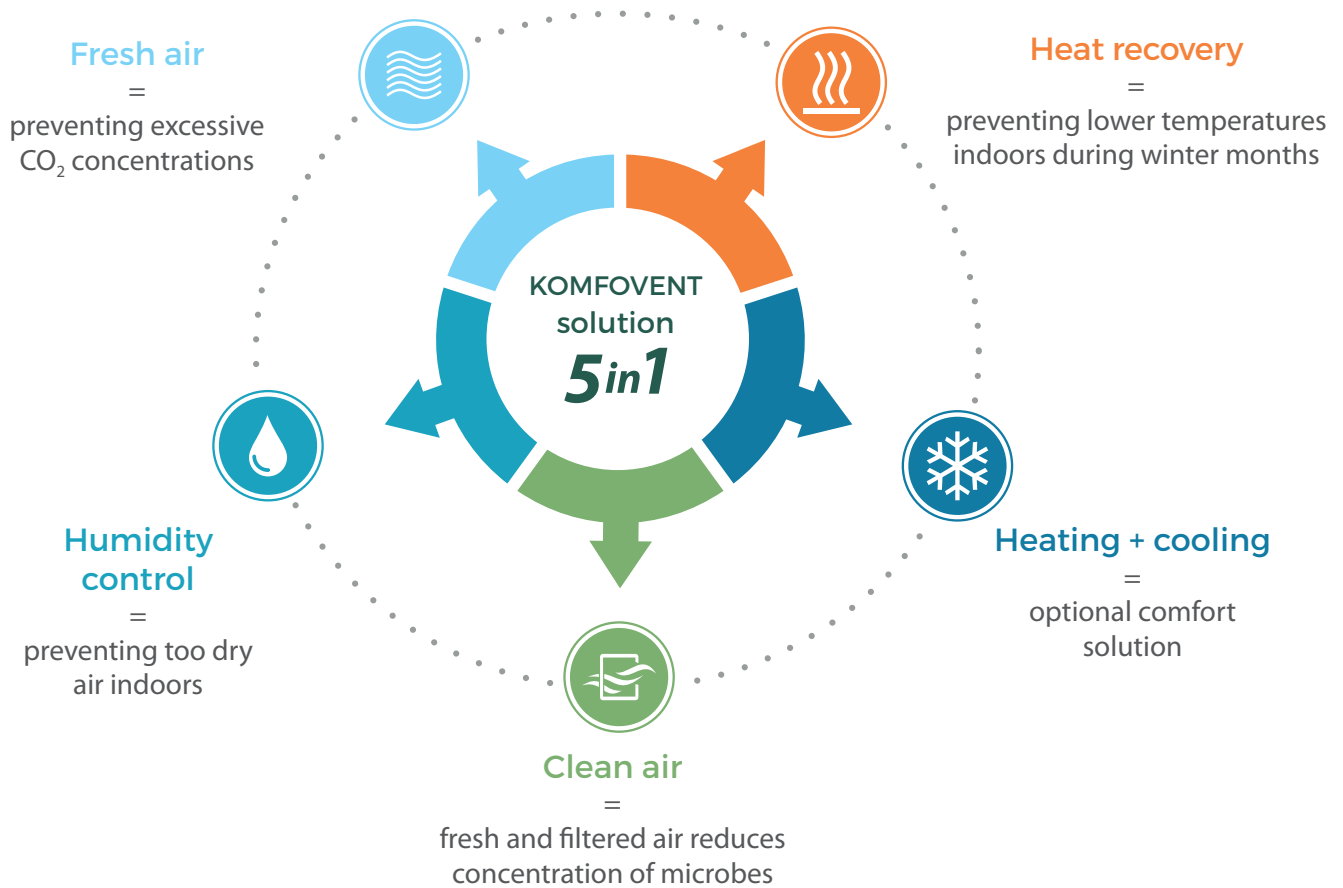

- ✔ **DECENTRALIZED:** separate ventilation unit for each room
- ✔ **AIR QUALITY** measurement: temperature, CO₂ and humidity levels
- ✔ **CENTRALIZED:** one ventilation unit for a part of the building or the entire building
- ✔ **DIGITAL CONTROL,** remote monitoring and maintenance
- ✔ **DUCT SYSTEM:** metal, plastic or fabric
- ✔ **AUTOMATIC** air volume control
- ✔ **NOISE INSULATION**
- ✔ **PERFORMANCE:** 700 – 40 000 m³/h

Decentralized ventilation without a duct system

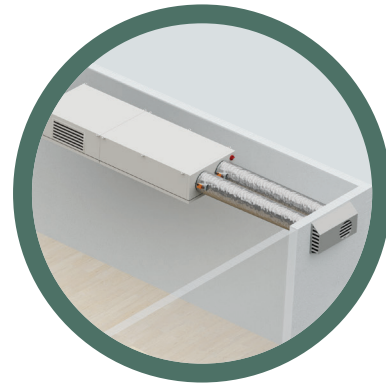
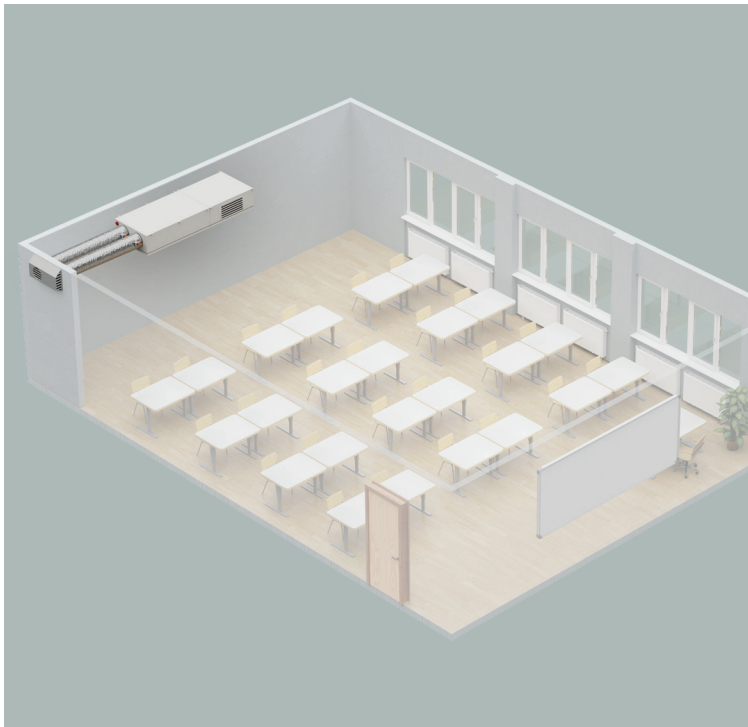

- Integrated silencers
- Integrated air supply and exhaust grille
- Motorized supply and exhaust dampers
- CO₂, humidity and temperature sensors
- Remote controller



Vertical unit – single room solution

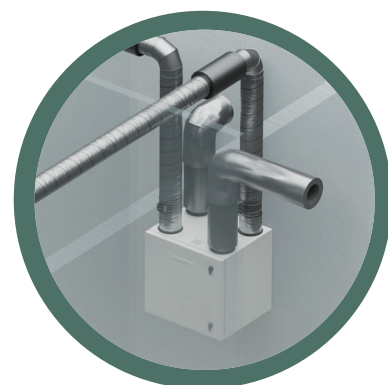
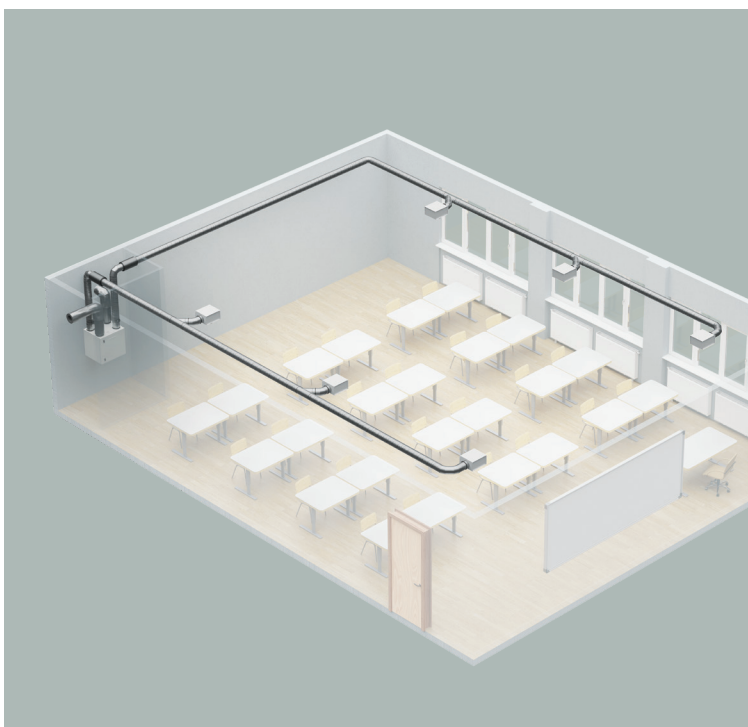

- Silencers
- Drywall cabinet
- Air dampers
- Supply and exhaust ducts
- CO₂, humidity and temperature sensors
- Control panel



Flat unit – single room solution

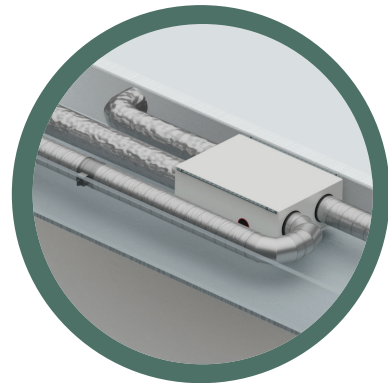
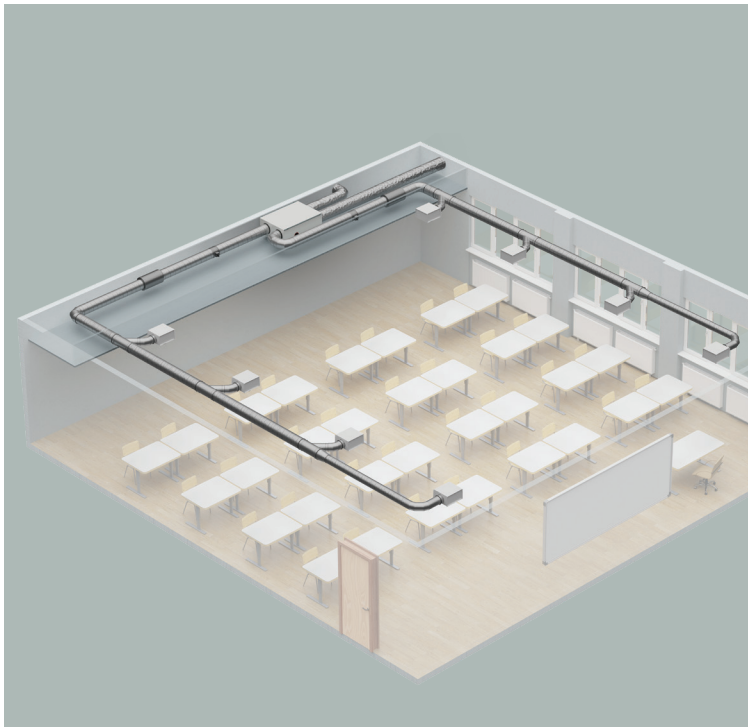

- Silencers
- Air dampers
- Supply and exhaust ducts
- CO₂, humidity and temperature sensors
- Control panel



Universal unit – solution for several rooms

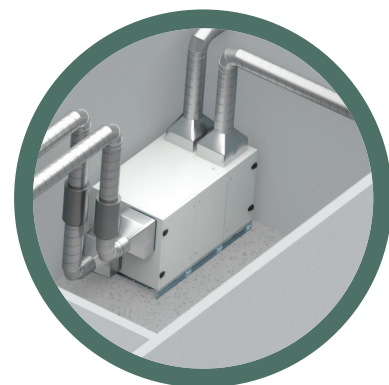
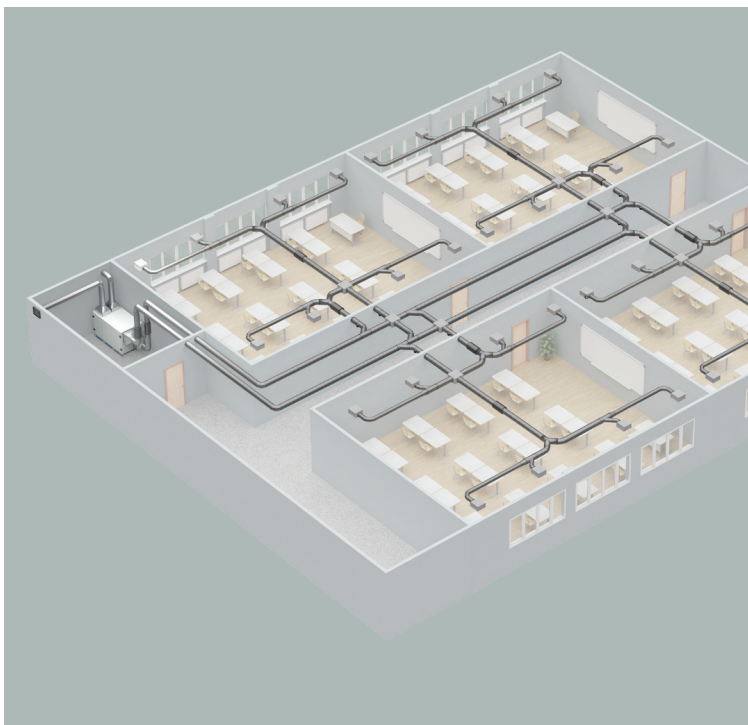

- Silencers
- Air dampers, VAV and fire dampers
- Supply and exhaust ducts
- CO₂, humidity and temperature sensors
- Control panel



Air handling unit for decentralized ventilation VERSO R 1000 FSA C5

The unit is intended to ventilate one room (classroom) by installing the unit to the ceiling



Technical data

Nominal air flow, m ³ /h / 100 Pa	1000
Nominal fan power, W	123
Noise at distance 3 m, dB(A)	35
Dimensions B × H × L, mm	1050 × 485 × 3000
Weight, kg	238
Thermal efficiency of heat recovery, %	77
Electric air heater capacity, kW	3

Performance

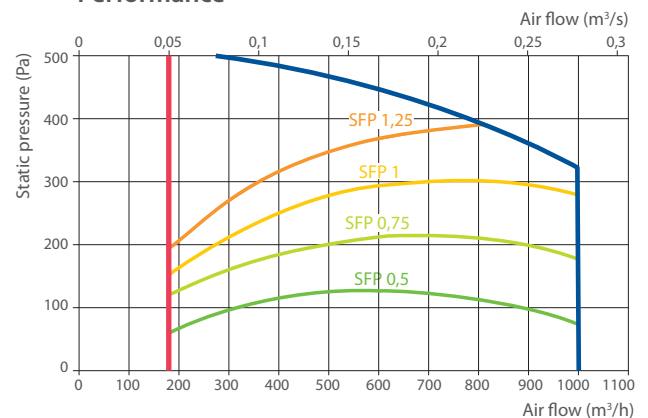

Right (R1)

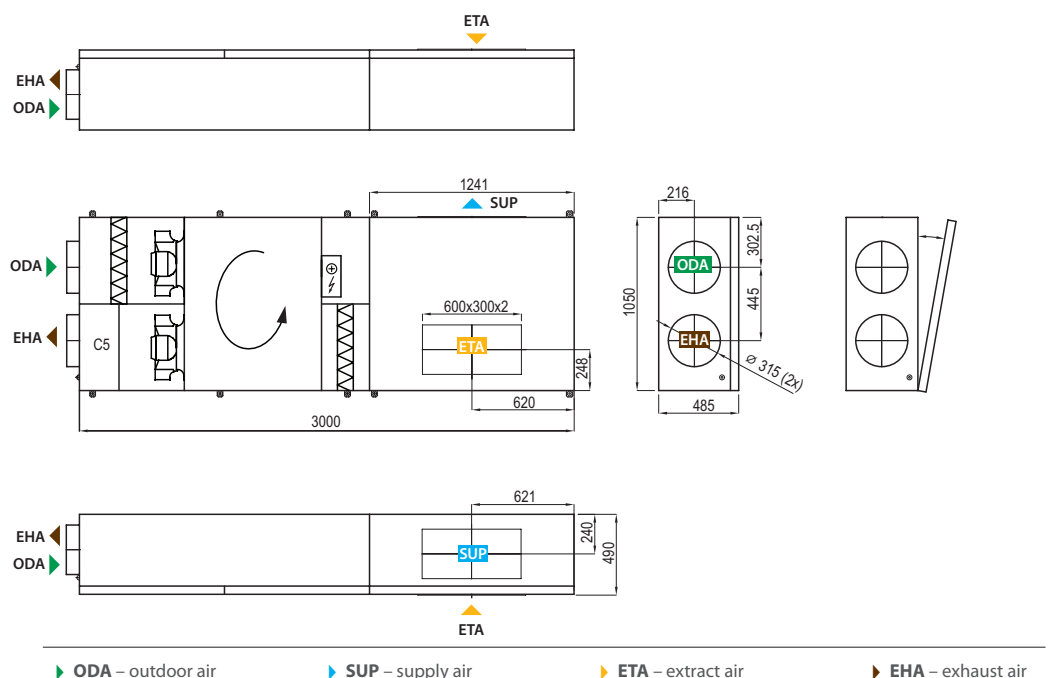



Our services

- Consultations and advice
- Supply of spare parts
- Warranty and post-warranty maintenance
- Quick response

KOMFOVENT UAB

Lentvario str. 146
25132 Vilnius, Lithuania
info@komfovent.com
www.komfovent.com