

komfovent[®]



VERSO Standard



INSTALLATION
MANUAL

EN

CONTENT

| | |
|---|----|
| 1. INTRODUCTION | 4 |
| 1.1. Safety Requirements | 4 |
| 1.2. Unit Types and Sizes | 4 |
| 1.2.1. Unit types by heat recovery type | 5 |
| 1.2.2. Unit types by duct connections | 6 |
| 1.2.3. Unit types by inspection sides | 6 |
| 1.3. Unit components | 7 |
| 1.3.1. Horizontal units | 7 |
| 1.3.2. Vertical units | 10 |
| 1.3.3. Flat units | 15 |
| 2. UNIT TRANSPORTATION | 18 |
| 3. MECHANICAL INSTALLATION | 20 |
| 3.1. Requirements for Mounting Location and Installation Base | 20 |
| 3.2. Inspection Area | 23 |
| 3.3. Connection of Sections | 24 |
| 3.4. Duct system installation | 27 |
| 3.5. Installation of External Heating/Cooling Devices | 29 |
| 3.6. Connection of a Condensate Drain | 30 |
| 3.7. Outdoor Units | 31 |
| 4. TECHNICAL INFORMATION | 32 |
| 5. UNIT DIMENSIONS | 33 |
| 5.1. Horizontal units | 33 |
| 5.2. Vertical units | 34 |
| 5.3. Flat units | 35 |
| 5.4. Units VERSO S | 36 |
| 6. ELECTRICAL INSTALLATION | 37 |
| 6.1. Requirements for Electrical Connection | 37 |
| 6.2. Connection of Electrical Components | 38 |
| 6.3. Control Panel Installation | 41 |
| 6.4. Connection of Cables and Wires Between Sections | 43 |
| 6.5. Connecting the Unit to the Internal Computer Network or the Internet | 44 |
| 7. FILTERS | 46 |
| 8. COMMISSIONING AND INSPECTION OF THE UNIT | 49 |
| 8.1. Control panel C5.1 | 49 |
| 8.2. Starting the Unit With a Computer | 51 |
| 8.3. Quick Inspection | 53 |

1. INTRODUCTION

This Installation Manual is intended for professionals, qualified to install VERSO Standard air handling units. Qualified professionals are people with sufficient professional experience and knowledge of ventilation systems and installation thereof, knowledge of electrical safety requirements and having ability to perform works without endangering themselves or others. See the KOMFOVENT website for user manuals.

1.1. Safety Requirements

To avoid misunderstandings, read this Instruction Manual carefully before installing air-handling unit.

Only a qualified professional in accordance with the manufacturer's instructions and applicable legal acts and safety requirements may install air-handling units. An air handling unit is an electrical-mechanical device that contains electrical and moving parts, therefore, disregarding instructions of this manual will void the manufacturer's warranty and may also cause direct damage to property or human health.



- Before starting any tasks, make sure that the unit is unplugged from the mains.
- Use caution when performing works near internal or external heaters as their surfaces may be hot.
- Do not connect the unit to the mains unless all the external assemblies are installed completely.
- Do not connect the unit to the mains in case of any visible damage incurred during transportation.
- Do not leave foreign objects and tools inside the unit.
- It is forbidden to operate air-handling units in areas with potentially explosive atmospheres.
- Use appropriate safety equipment (gloves, goggles) when performing installation or repair works.



This symbol indicates that this product may not be disposed of with your household waste as specified in WEEE Directive (2002/96/EC) and national laws. This product should be handed over to a designated collection point or to an authorised collection site for recycling waste electrical and electronic equipment (EEE). Improper handling of this type of waste could have a negative impact on the environment and human health due to potentially hazardous substances that are generally associated with electrical and electronic equipment. At the same time, your cooperation in the correct disposal of this product will contribute to the effective usage of natural resources. For more information about where you can drop off your waste equipment for further recycling, contact your city authorities, waste management organisations, approved WEEE scheme or your household waste disposal service.

1.2. Unit Types and Sizes

An air-handling unit is a device designed to ensure good ventilation in the premises. An air-handling unit removes indoor air containing carbon dioxide, various allergens or dust, while replacing it with filtered fresh air from outside. As the outside air is usually colder or warmer than the air within the premises, an integrated recuperator (heat exchanger) collects thermal energy from the indoor air and transfers the majority of it to the supply air. When a recuperator is not capable of reaching a desired temperature, additional heaters or coolers may be activated.



Heat exchangers and heaters (or coolers) are designed to compensate for heat/cool losses during ventilation, therefore, we do not recommend using this unit as the main heating/cooling source. The unit may fail to reach a user-defined supply air temperature when the actual temperature in the premises differs significantly from the temperature set point, since this will lead to inefficient operation of a heat exchanger.

VERSO STANDARD air handling units are manufactured in different sizes and various air flow ranges (from 1000 to 7000 m³/h).

1.2.1. Unit types by heat recovery type

All VERSO Standard air handling units are divided into 3 groups according to the type of recuperator (heat exchanger) used:

VERSO R - air handling units with rotary heat exchangers. Rotating wheel (rotor) of a rotary heat exchanger collects heat or cold from the indoor air and transfers it to the fresh supply air. Recovered heat/cold capacity is changed by adjusting the rotor speed. When heat recovery is not required, the wheel stops.

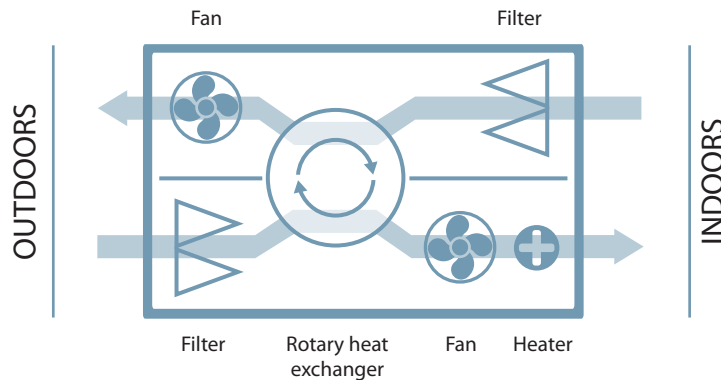

VERSO CF – air handling units with counter-flow recuperators (heat exchangers). Plates of a heat exchanger come in contact with different air flows and so heat exchange between extracted and incoming fresh supply air takes place. Amount of recovered heat or cold is controlled by adjusting the air bypass damper position. When recuperation is not required, the air bypass damper is opened and the heat exchanger is closed. This way, the outdoor air bypasses the heat exchanger and flows directly in to the premises.

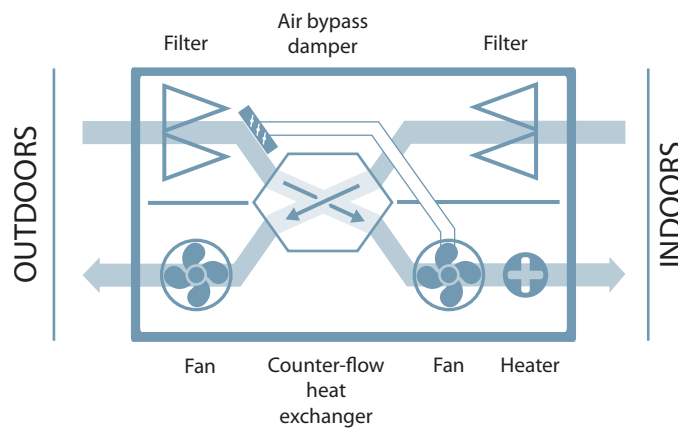

During operation of AHU with counter-flow heat exchanger condensate is forming and it can freeze at negative outdoor temperatures. If there is a risk of freezing, heat exchanger defrost procedure is started (see user manual). During the defrosting cycle an air bypass damper is opened and cold outdoor air is directed to heating devices bypassing the heat exchanger, therefore, during the defrosting cycle the supply air temperature briefly decreases. To reduce temperature fluctuations during defrosting and to ensure that the heat exchanger will not freeze, even at very low outdoor temperatures, it is recommended to install a preheater, which should heat up air entering AHU to at least -4°C.

VERSO S – air handling units without heat exchangers, intended solely for air supply to the premises. Fresh outdoor air is heated/cooled to desired temperature with heating/cooling devices installed in the unit or air ducts.

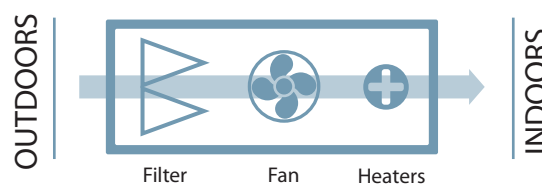

1.2.2. Unit types by duct connections

Depending on the installation and connection of the ducts, the air handling units are divided into:

- **Vertical units** (marked by the letter V) – when all ducts are connected at the top of the unit.
- **Horizontal units** (marked by the letter H) – when all ducts are connected on the sides of the unit.
- **Flat units** (marked by the letter F) – thinner units, which are designed for mounting over suspended ceilings. All ducts are connected on the sides of the unit.
- **Universal units** (marked by the letter U) – which duct connections can be relocated from the sides of the unit to the top and vice versa. Each universal unit has 16 different duct layout options that are easy to change during installation, depending on the intended installation location.

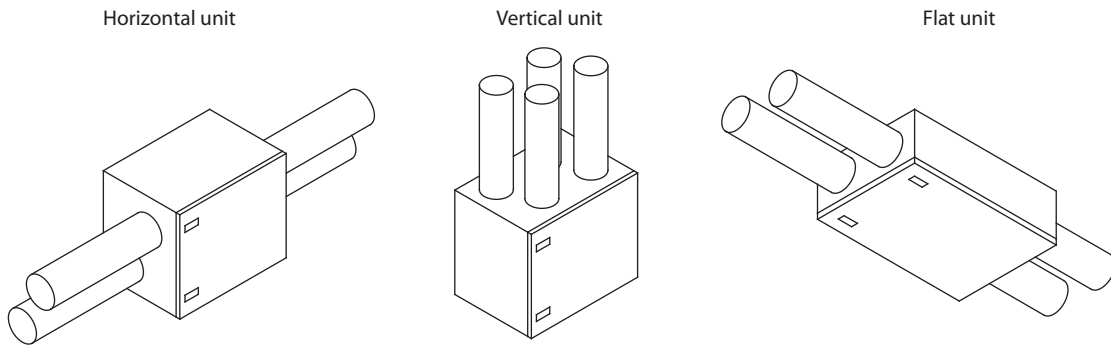

Fig. 1. Classification of units by duct connection

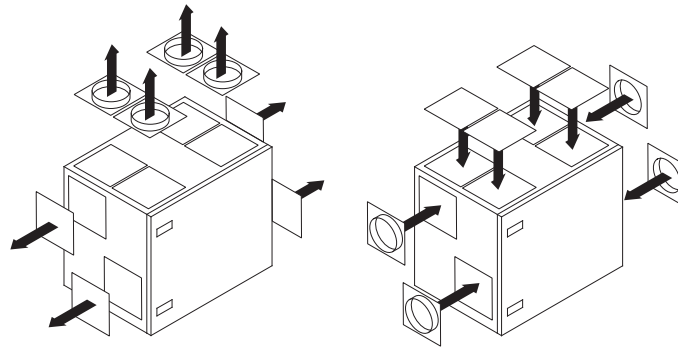

Fig. 2. Relocation of duct connections of the universal units

1.2.3. Unit types by inspection sides

Also, each unit may be left or right inspection side¹. The inspection side indicates which side of the unit contains the air supply duct to the premises. The exact arrangement of the duct connections for the different inspection sides can be found in section "Unit components".

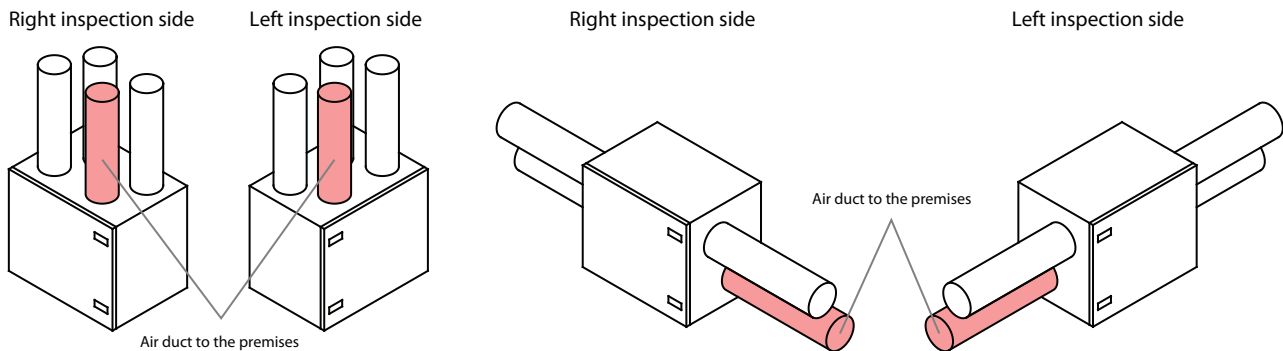

Fig. 3. Classification of units by inspection side

¹ Depends on your order.

1.3. Unit components

Below are the principal diagrams of air handling units, including the marking of assemblies of the unit and the arrangement of the duct connections.

1.3.1. Horizontal units

VERSO R 1000 UH - 1300 UH - 1500 UH - 1700 UH - 2000 UH

Right Inspection side R1

Left inspection side L1

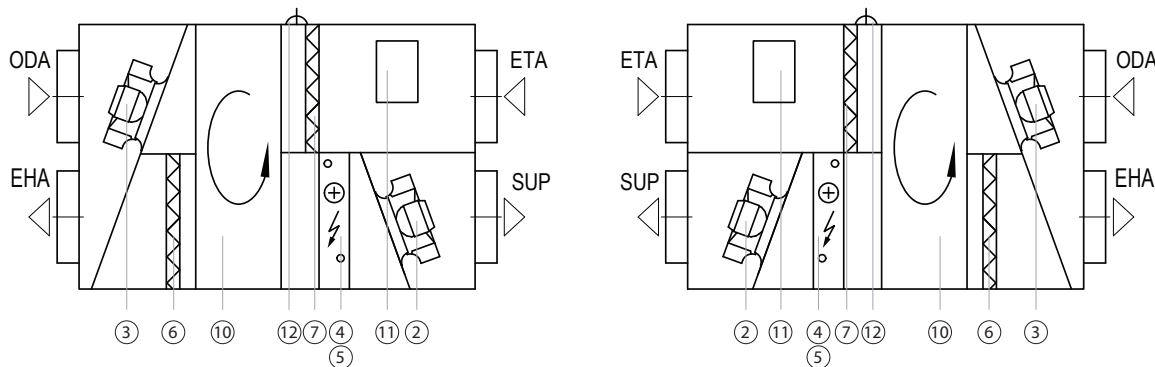

VERSO R 2500 H

Right Inspection side R1

Left inspection side L1

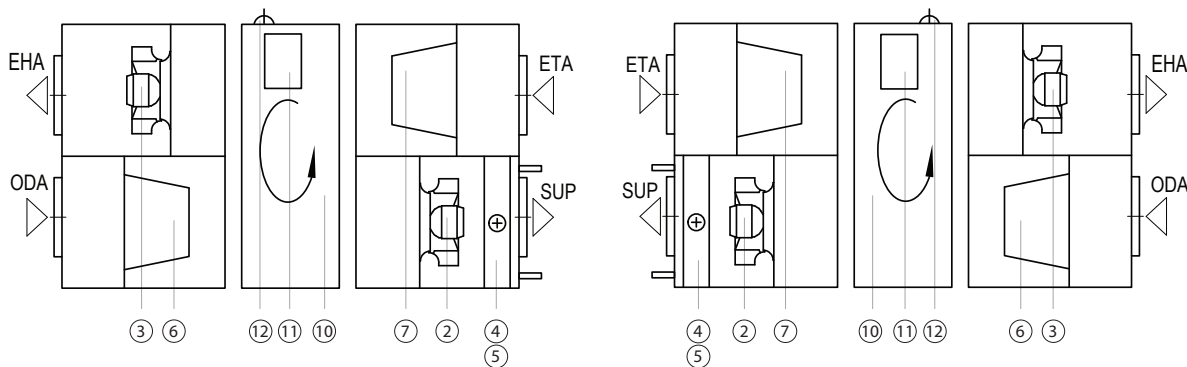

Right Inspection side R2

Left inspection side L2

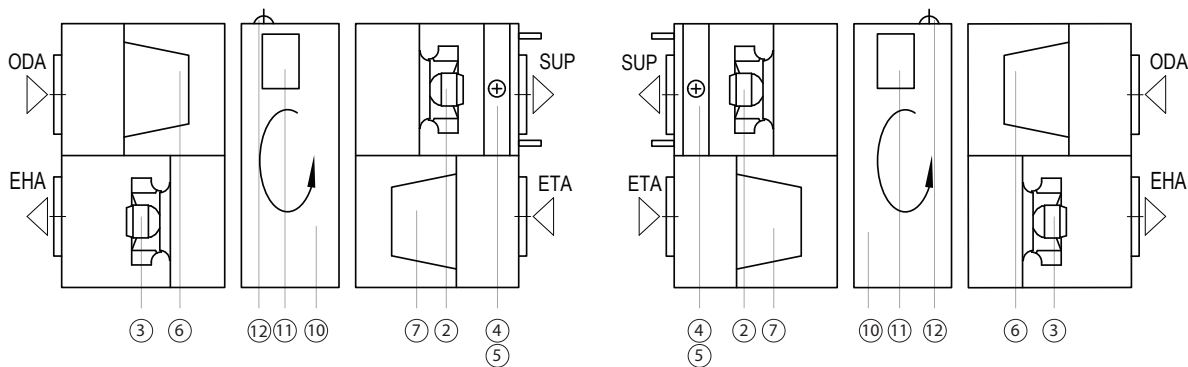

VERSO R 3000 UH - 4000 UH

Right Inspection side R1

Left inspection side L1

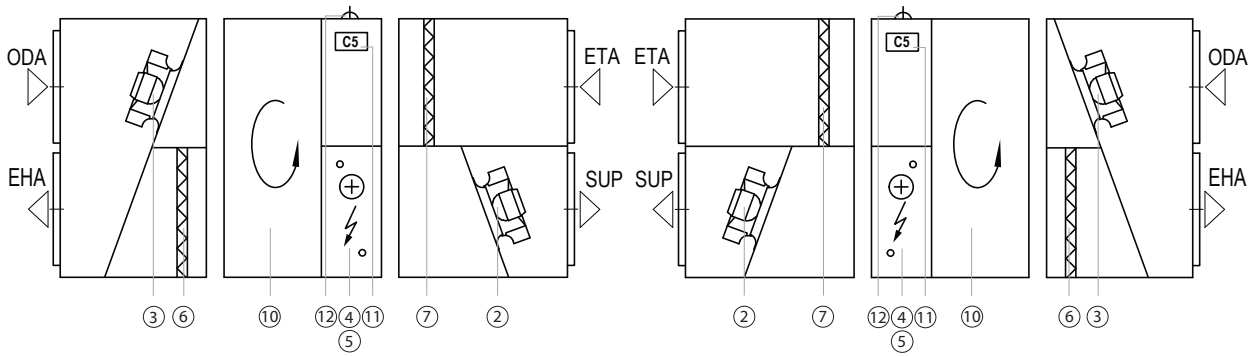

VERSO R 5000 H

Right Inspection side R1

Left inspection side L1

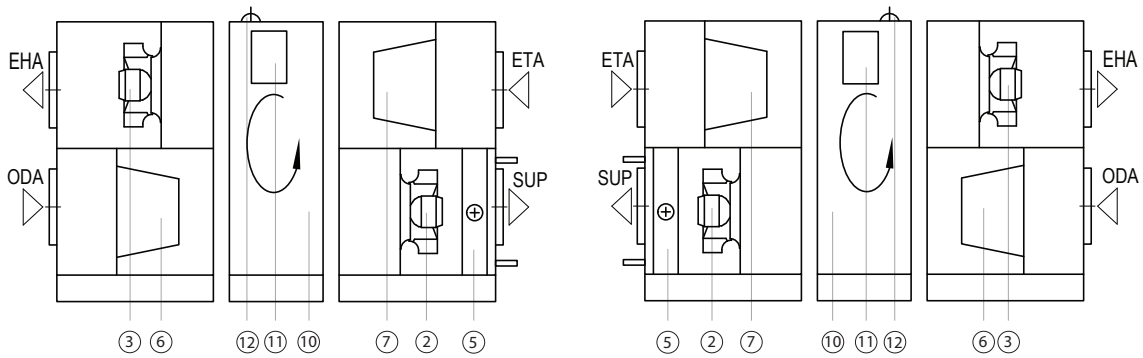

Right Inspection side R2

Left inspection side L2

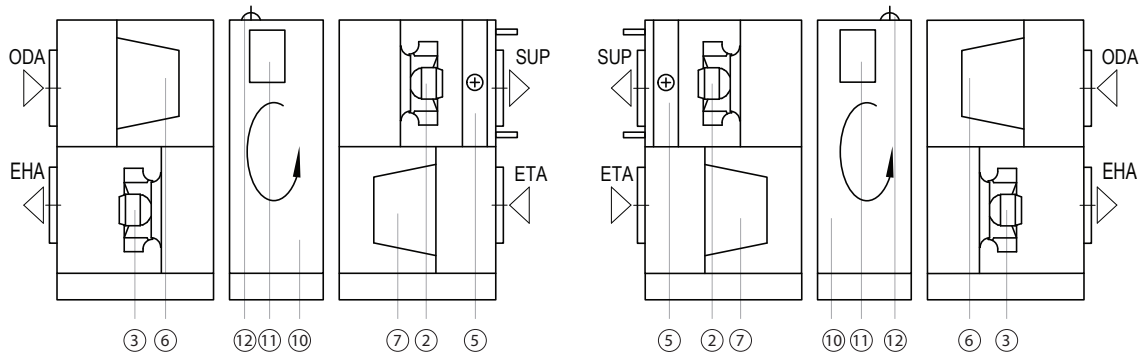

VERSO R 7000 H

Right Inspection side R1

Left inspection side L1

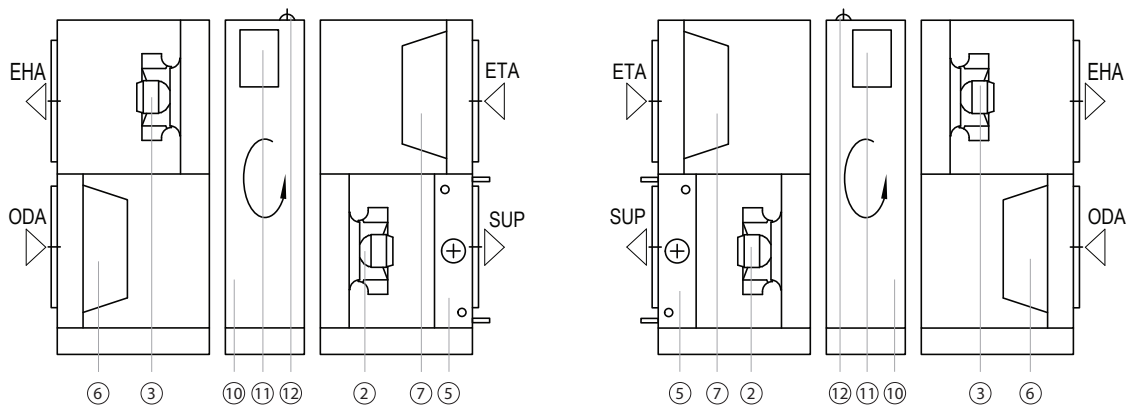

VERSO CF 1000 UH - 1300 UH - 1700 UH

Right Inspection side R1

Left inspection side L1

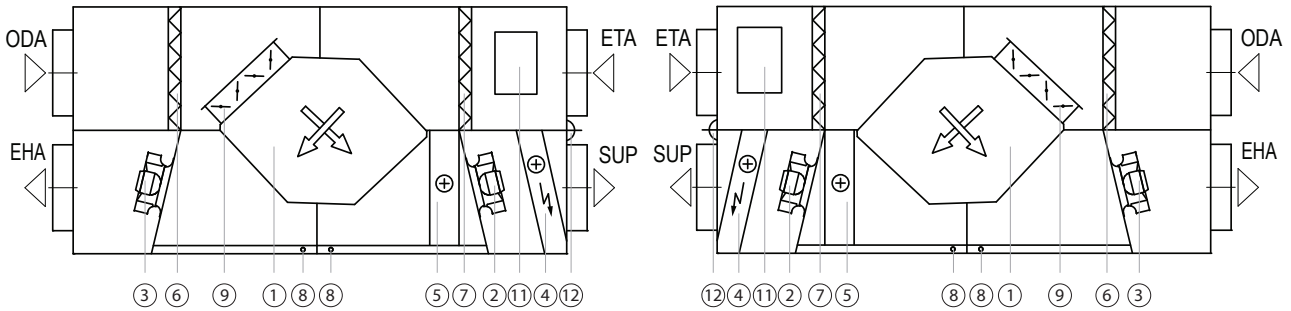

VERSO CF 2300 UH

Right Inspection side R1

Left inspection side L1

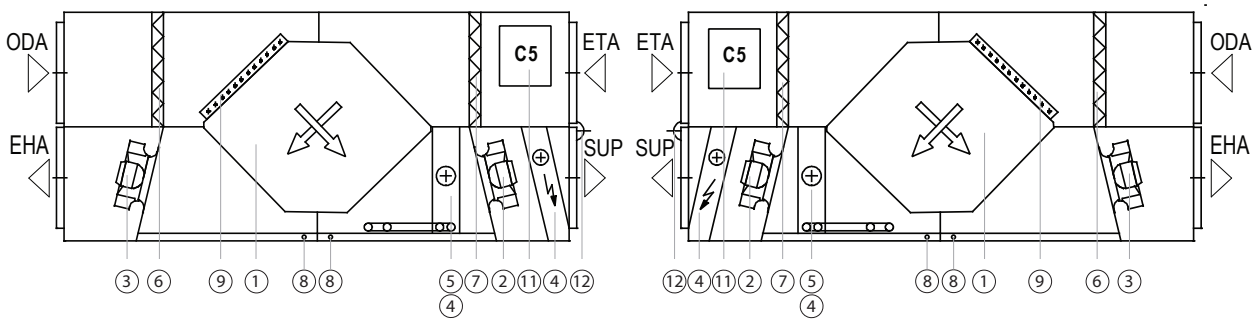



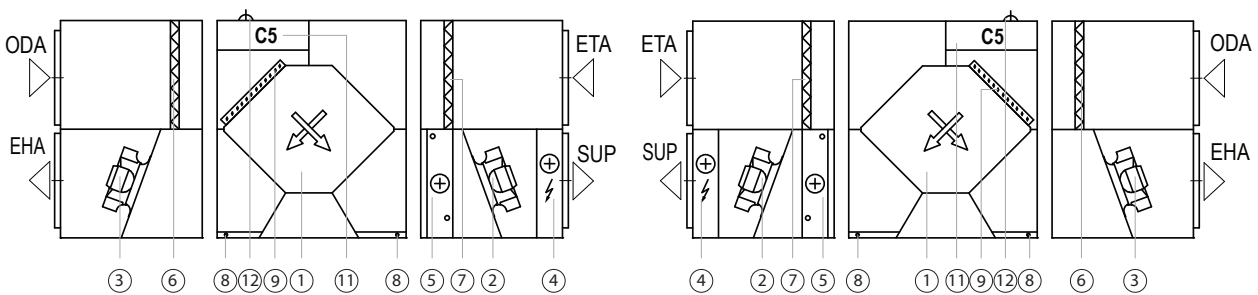

VERSO CF 3500 UH

Right Inspection side R1

Left inspection side L1



-  **ODA** – outdoor air
-  **SUP** – supply air
-  **ETA** – extract air
-  **EHA** – exhaust air

- 1 – counterflow heat exchanger
- 2 – supply air fan
- 3 – extract air fan
- 4* – electric heater
- 5* – water heater / cooler / DX
- 6 – outdoor air filter

- 7 – indoor air filter
- 8 – condensate drain
- 9 – air bypass valve
- 10 – rotary heat exchanger
- 11 – C5 controller main board
- 12 – Lead-in wire

* Depending on the order.

1.3.2. Vertical units

VERSO R 1000 UV - 1300 UV - 1500 UV

Right Inspection side R1

Left inspection side L1

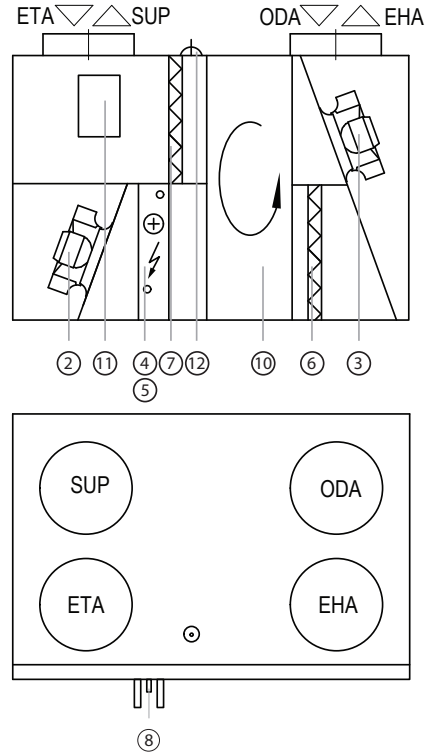
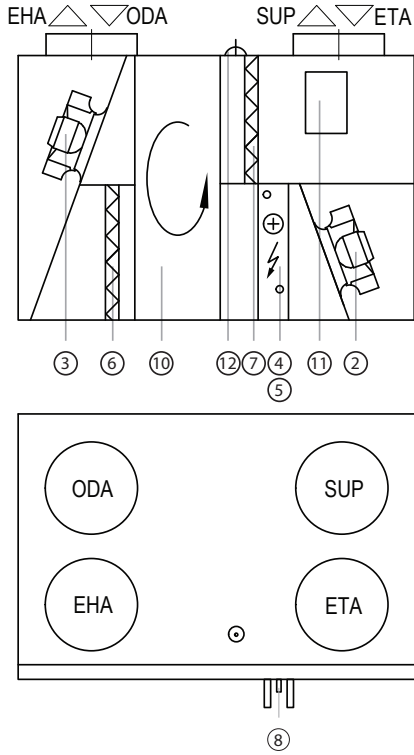

VERSO R 1700 UV - 2000 UV

Right Inspection side R1

Left inspection side L1

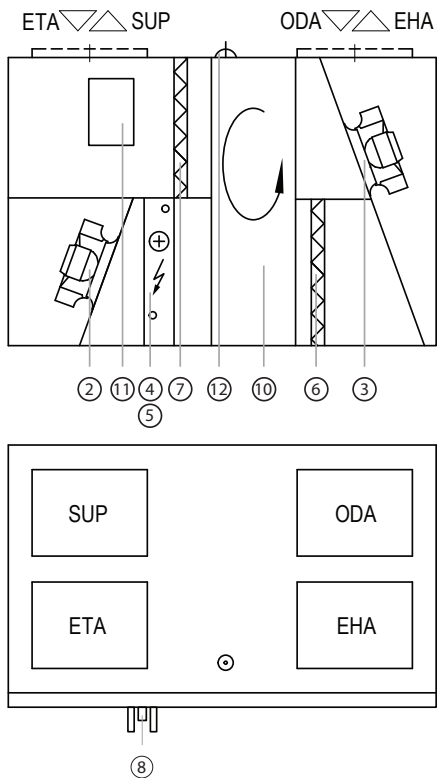
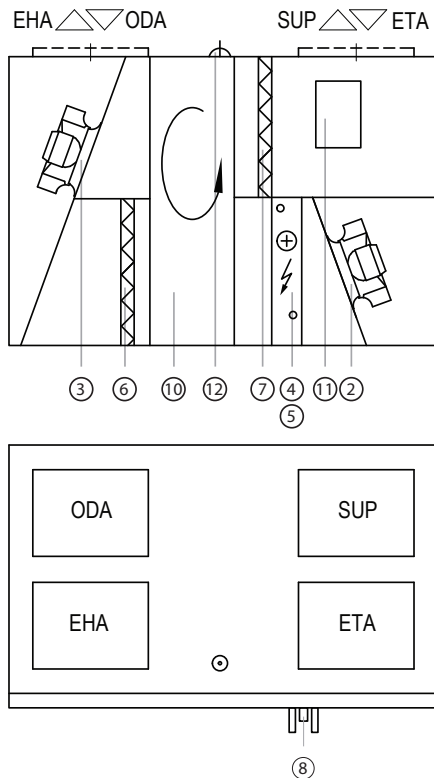

VERSO R 3000 UV - 4000 UV

Right Inspection side R1

Left inspection side L1

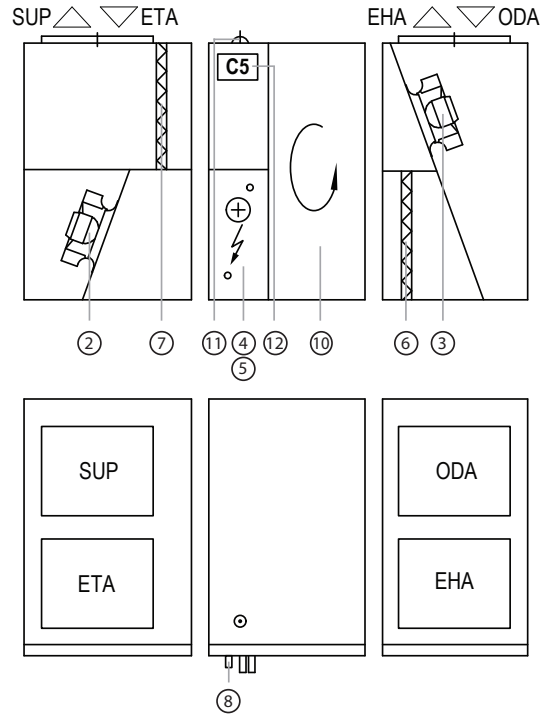
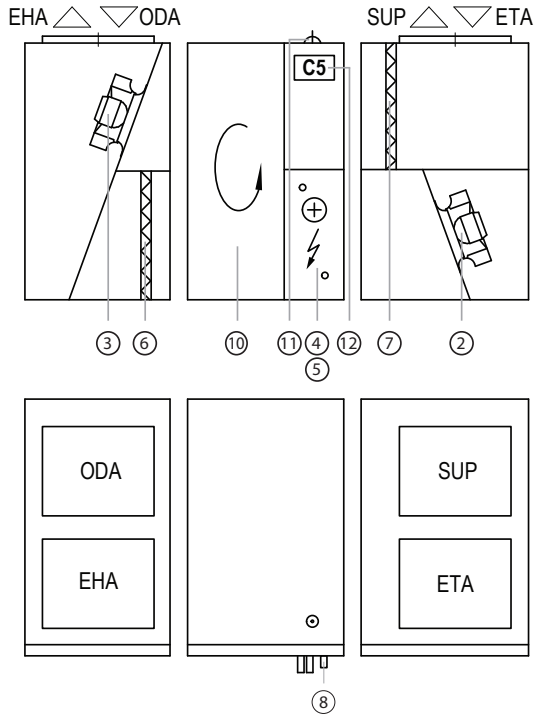

VERSO R 5000 V HW/HCW/DX

Right Inspection side R1

Left inspection side L1

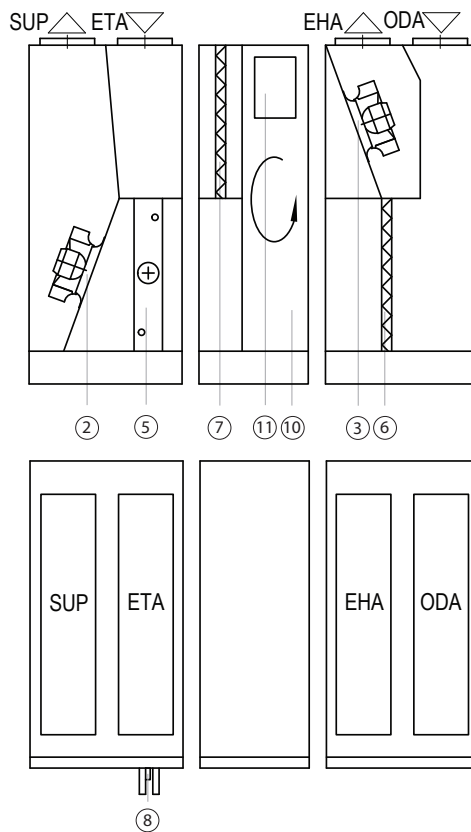
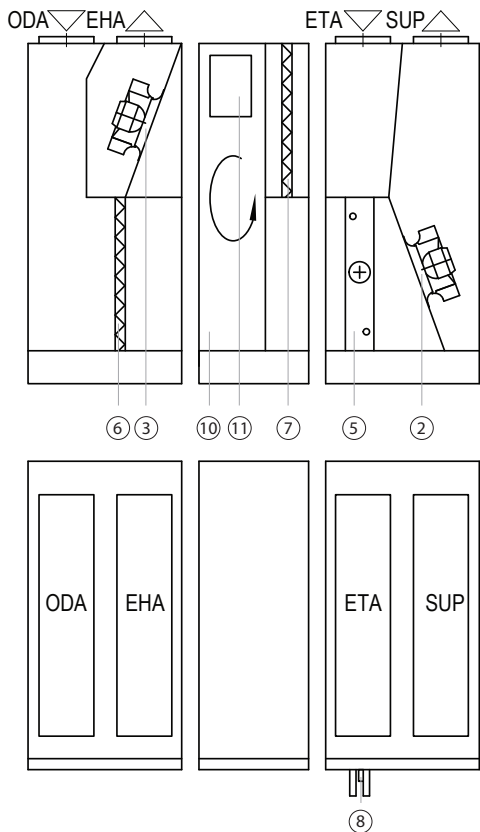

VERSO R 5000 V HE

Right Inspection side R1

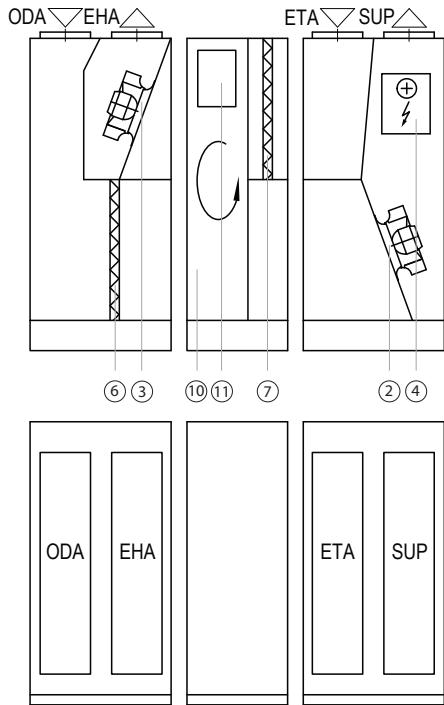

Left inspection side L1

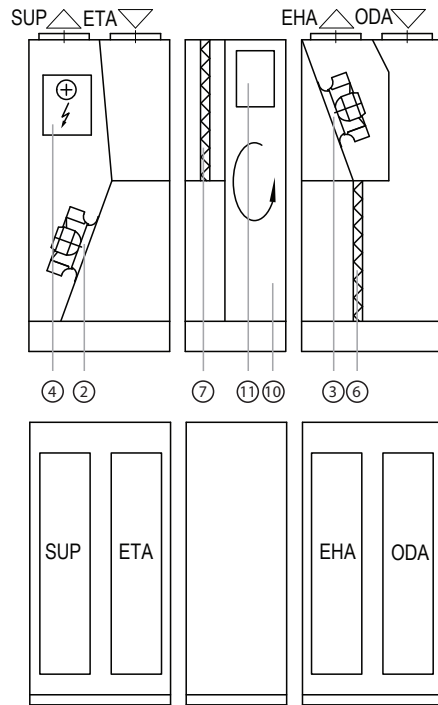

VERSO R 7000 V

Right Inspection side R1

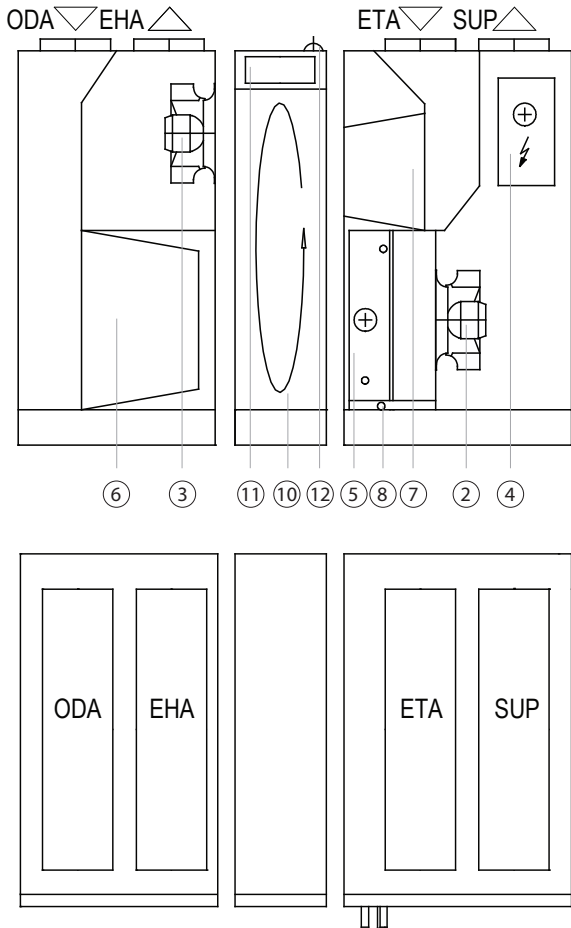

Left inspection side L1

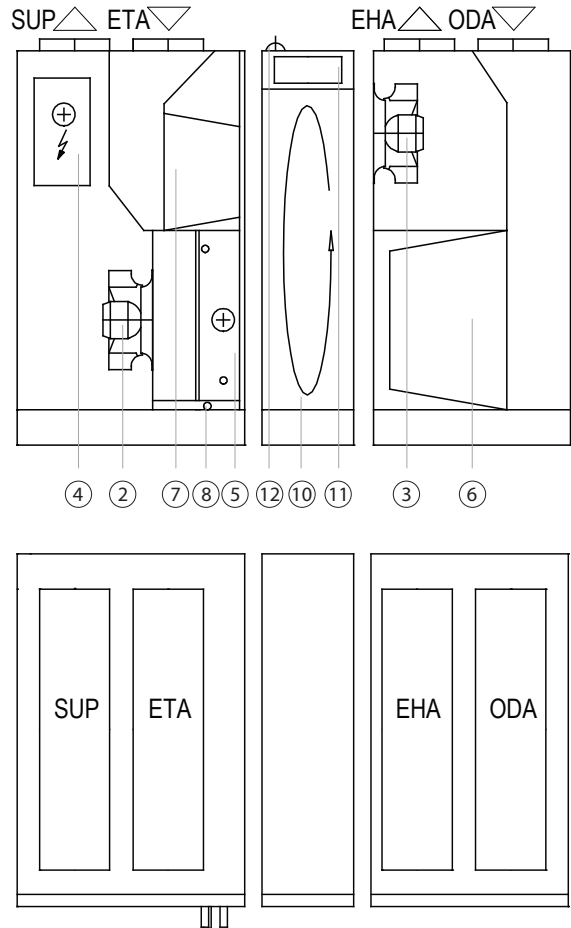

VERSO CF 1000 UV - 1300 UV - 1700 UV

Right Inspection side R1

Left inspection side L1

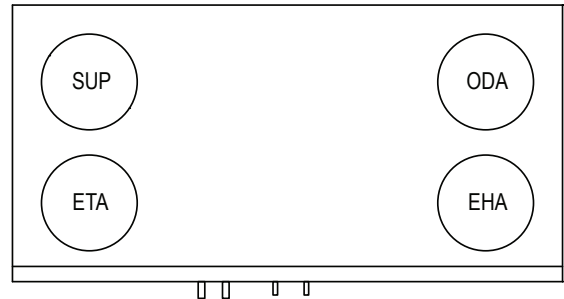
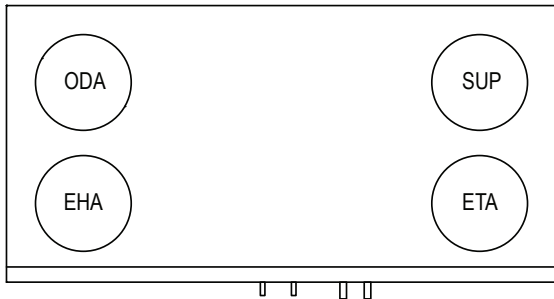
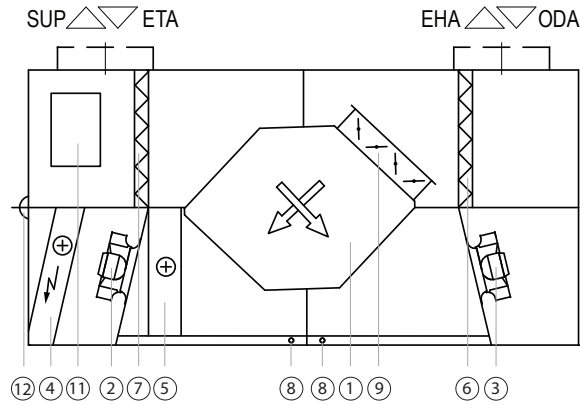
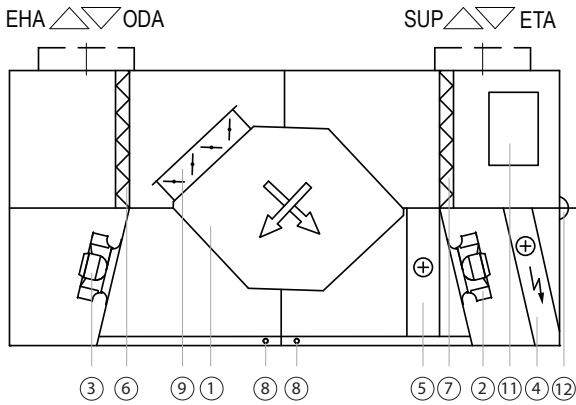

VERSO CF 2300 UV

Right Inspection side R1

Left inspection side L1

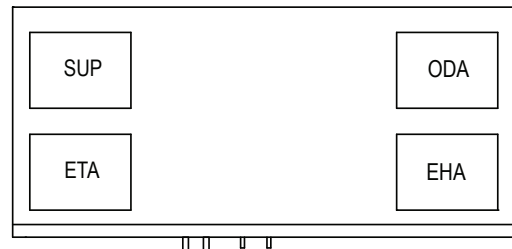
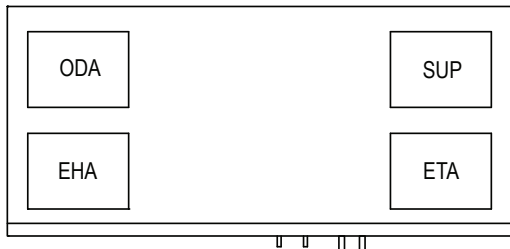
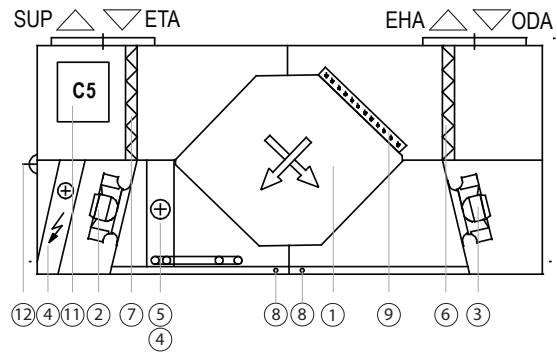
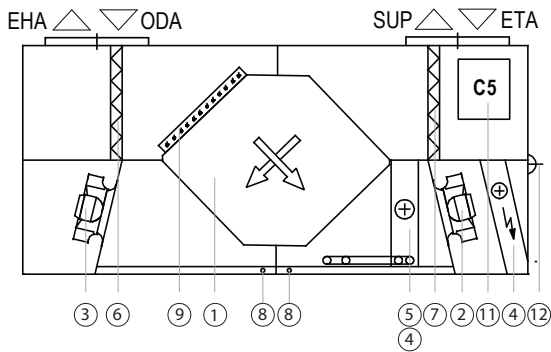

VERSO CF 3500 UV

Right Inspection side R1

Left inspection side L1

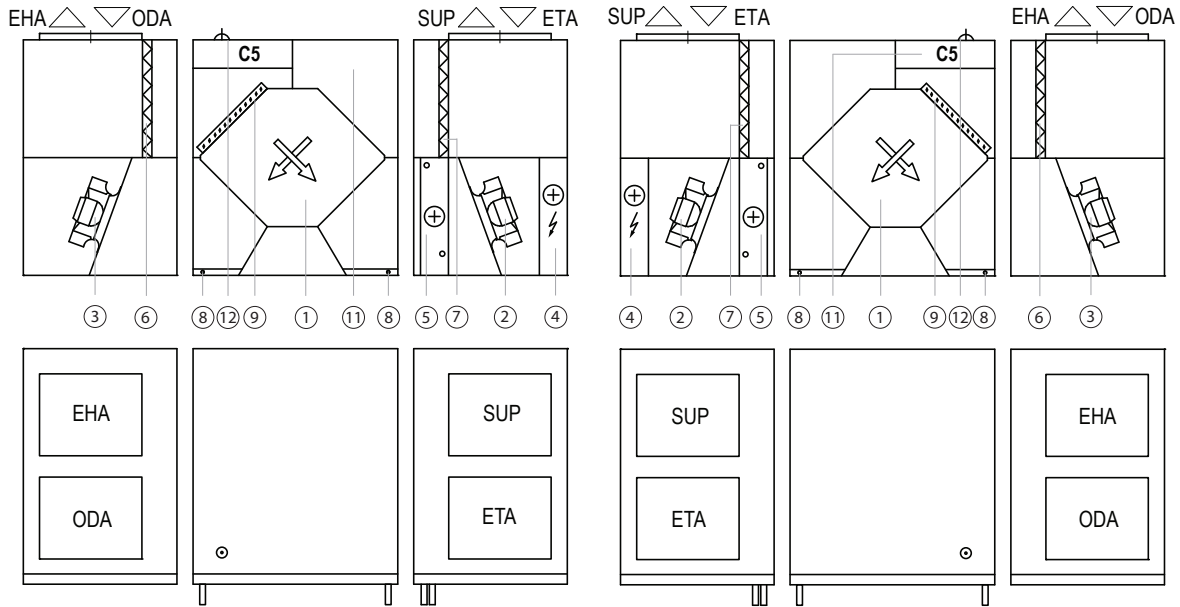



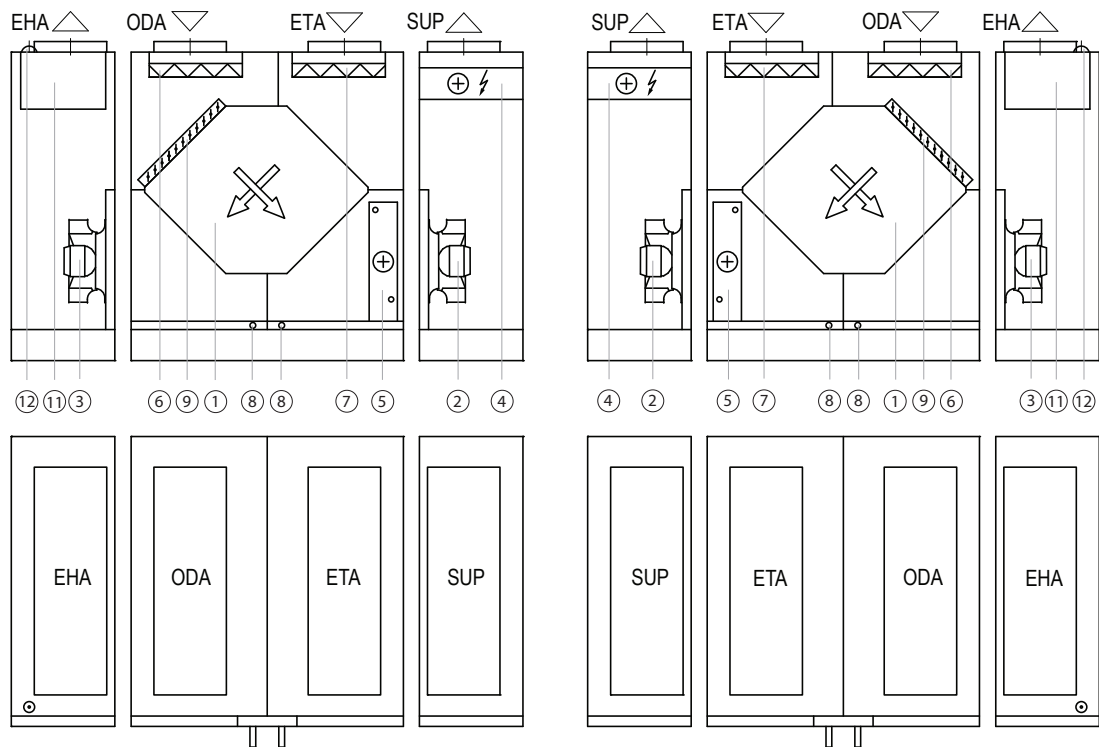

VERSO CF 5000 V

Right Inspection side R1

Left inspection side L1



-  ODA – outdoor air
-  SUP – supply air
-  ETA – extract air
-  EHA – exhaust air

- 1 – counterflow heat exchanger
- 2 – supply air fan
- 3 – extract air fan
- 4* – electric heater
- 5* – water heater / cooler / DX
- 6 – outdoor air filter

- 7 – indoor air filter
- 8 – condensate drain
- 9 – air bypass valve
- 10 – rotary heat exchanger
- 11 – C5 controller main board
- 12 – Lead-in wire

* Depending on the order.

1.3.3. Flat units

VERSO R 1000 FSA

Right Inspection side R1

Left inspection side L1

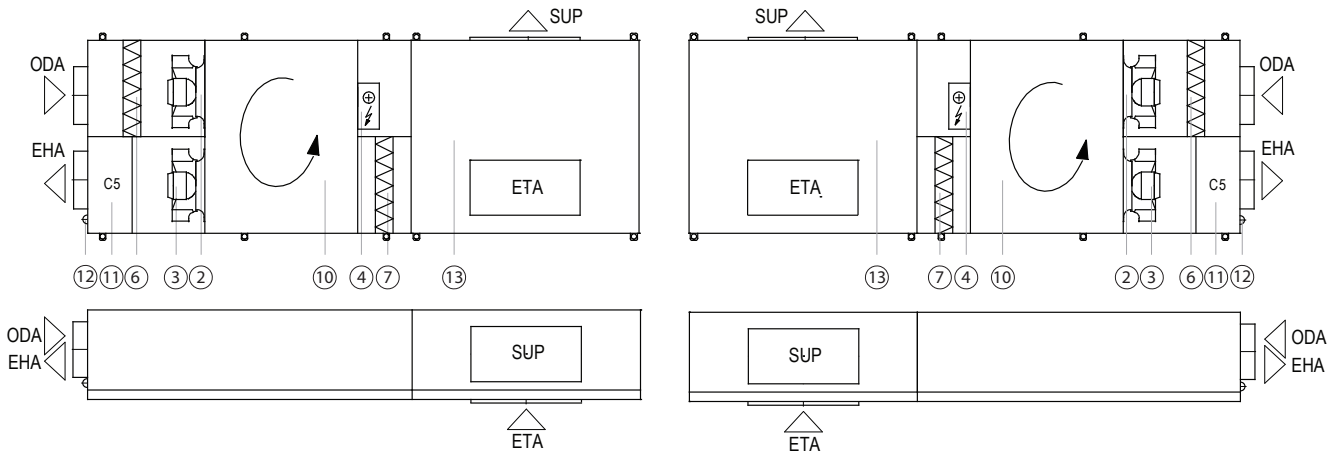

VERSO R 1300 F

Right Inspection side R2/L1

Left inspection side L2/R1

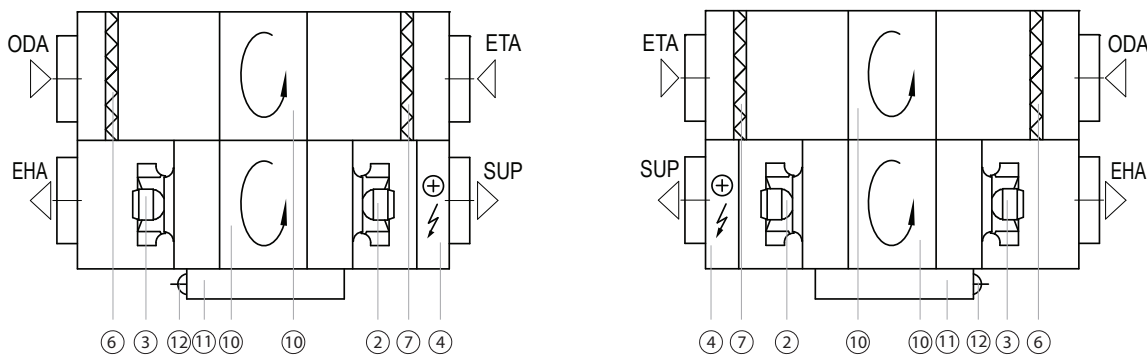

VERSO R 2000 F

Right Inspection side R2/L1

Left inspection side L2/R1

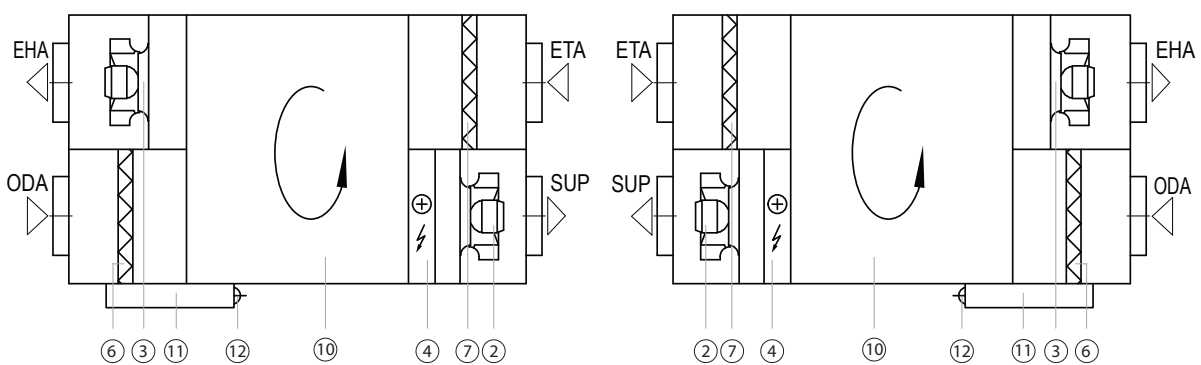

- ODA – outdoor air
- SUP – supply air
- ETA – extract air
- EHA – exhaust air

- 1 – counterflow heat exchanger
- 2 – supply air fan
- 3 – extract air fan
- 4* – electric heater
- 5* – water heater / cooler / DX
- 6 – outdoor air filter
- 7 – indoor air filter

- 8 – condensate drain
- 9 – air bypass valve
- 10 – rotary heat exchanger
- 11 – C5 controller main board
- 12 – Lead-in wire
- 13 – Noise suppressor section

* Depending on the order.

VERSO R 3000 F

Right Inspection side R2/L1

Left inspection side L2/R1

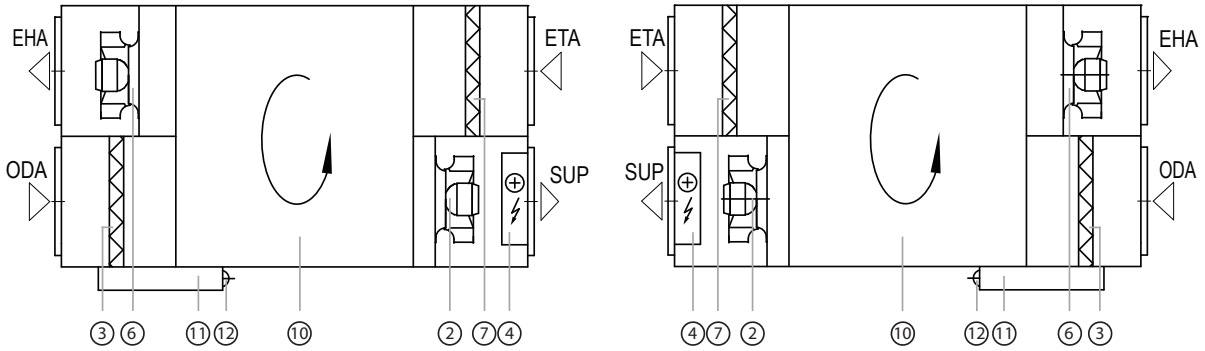

VERSO CF 1000 F - 1300 F - 1500 F

Right Inspection side R2/L1

Left inspection side L2/R1

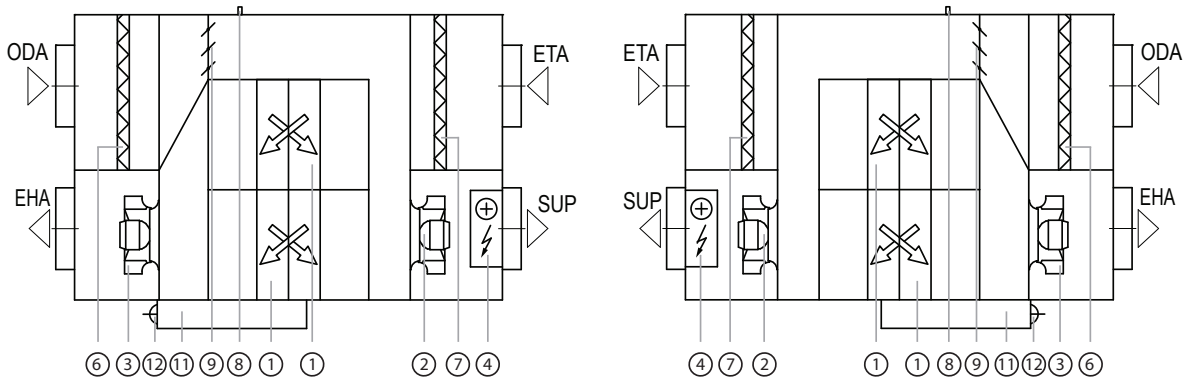

VERSO CF 2500 F

Right Inspection side R2/L1

Left inspection side L2/R1

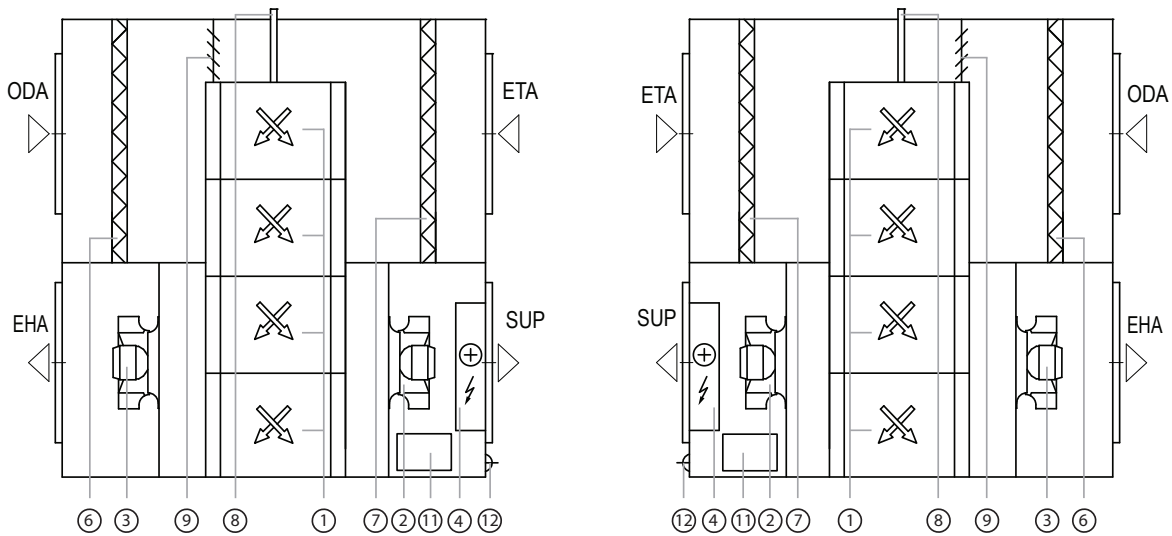



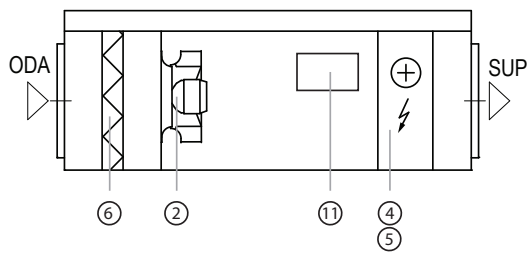

VERSO S 1300 F - 2100 F

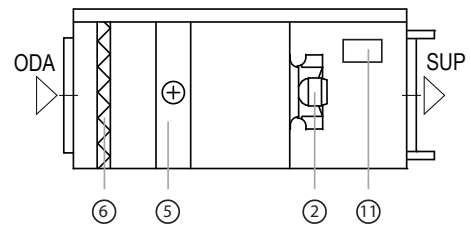

VERSO S 3000 F



-  **ODA** – outdoor air
-  **SUP** – supply air
-  **ETA** – extract air
-  **EHA** – exhaust air

- 1 – counterflow heat exchanger
- 2 – supply air fan
- 3 – extract air fan
- 4 – electric heater
- 5* – water heater / cooler / DX
- 6 – outdoor air filter
- 7 – indoor air filter

- 8 – condensate drain
- 9 – air bypass valve
- 10 – rotary heat exchanger
- 11 – C5 controller main board
- 12 – Lead-in wire
- 13 – Noise suppressor section

* Depending on the order.

2. UNIT TRANSPORTATION

Equipment must be transported and stored in the original packaging. During transportation, equipment must be properly secured and further protected against possible mechanical damage, rain or snow.

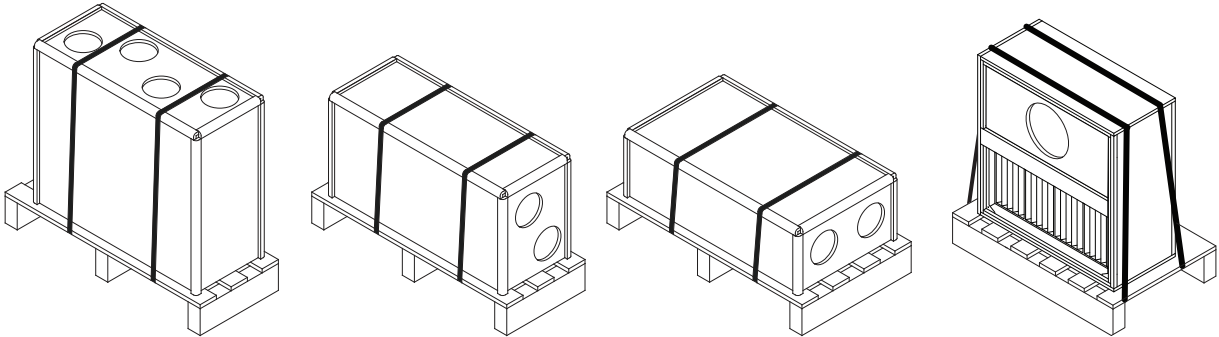

Fig. 4. Examples of equipment packaging

Forklift truck or crane can be used for loading or unloading. For the crane operation, special lashes or ropes must be used to securing them in the designated areas. Ensure that lifting lashes or ropes do not crush or otherwise damage the housing of the unit. We recommend using special belt supports. When lifting and transporting the equipment with a forklift, the forks must be long enough to prevent the unit from being overturned or mechanically damaging its bottom side. Air handling units are heavy, therefore, be careful during lifting, moving or transportation. Use personal protective equipment. Even small units should be transported on a forklift, a trolley or carried by multiple persons.



Fig. 5. Examples of transportation by crane, forklift and trolley

After delivery of the air handling unit, carefully inspect its packaging for damage. If mechanical or other damage is visible (e.g., wet cardboard packaging), notify the carrier immediately. If the damage is significant, do not accept the unit. Inform the selling company or the representative of UAB KOMFOVENT within three business days about any damage detected during delivery.¹

Units should be stored in a clean, dry room at a temperature of 0–40°C. When selecting a storage location, make sure the unit is not accidentally damaged, that other heavy objects are not loaded on top and dust or moisture does not get inside the unit.



Air handling units are heavy, therefore care must be taken during lifting, carrying or moving operations. Use personal protection equipment, do not stand under a suspended unit or a part thereof.



- Only an employee qualified to operate a forklift truck or crane and familiar with the principles of cargo lifting and safety requirements, must perform unloading or lifting operations.
- It must be ensured that the casing is not crushed or otherwise damaged by straps or ropes during lifting operations. Use of special supporting structures (traverses) is recommended.
- When lifting the unit or section thereof, note that their center of gravity may differ from the geometric center of the load.
- Mounting of separate air handling units in stacks is not allowed unless it's construction design is intended for such installation.
- Before installation AHU must be stored in clean and dry premises in their original packaging. If the unit is installed but not yet in use, all connection openings must be tightly closed and the unit must be additionally protected against environmental influences (dust, rain, cold, etc.).

¹ UAB KOMFOVENT is not responsible for losses caused by the carrier during transportation and unloading.

3. MECHANICAL INSTALLATION

3.1. Requirements for Mounting Location and Installation Base

VERSO Standard air handling units are designed for ventilation of medium or large commercial or industrial premises (e.g., stores, offices, hotels, etc.) where standard air temperature and humidity is maintained. These units are not intended for transporting solid particles within air flows. Standard equipment air handling units are intended for indoor installation; and with additional accessories, these units may be mounted outdoors. Air handling units are designed for ambient temperatures from -30°C to +40°C.



- **VERSO Standard units are not intended for operation in areas with potentially explosive atmospheres. Air handling units are not designed for ventilation and dehumidification of wet areas (pools, saunas, car washes, etc.).**
- **If the AHU is installed in a room with high humidity level, condensate may form on the walls of the unit at low outdoor temperatures.**

An air handling unit must be mounted on a relatively large and sturdy base, based on the weight of the unit and in accordance with building regulations. Base must be made of reinforced concrete or metal structures. If the unit is not equipped with adjustable height feet, it must be installed on a flat base. Vibration dampening gaskets must be fitted between the unit and installation base.



The outdoor air handling units must be fixed to the installation base (e.g., metal angle pieces with rubber vibration dampening gaskets).

Units installed on such base must be levelled in respect to the horizon – deviations shall not exceed 0.3mm for 1m in the longitudinal direction and 0.5mm for 1m in the transverse direction. If installation base is uneven, it is recommended to install the unit on the mounting frame with adjustable feet, which should be ordered separately. Some units are manufactured with factory-assembled mounting frame for separate sections of the unit. If necessary, adjustable feet may be ordered for such frame.

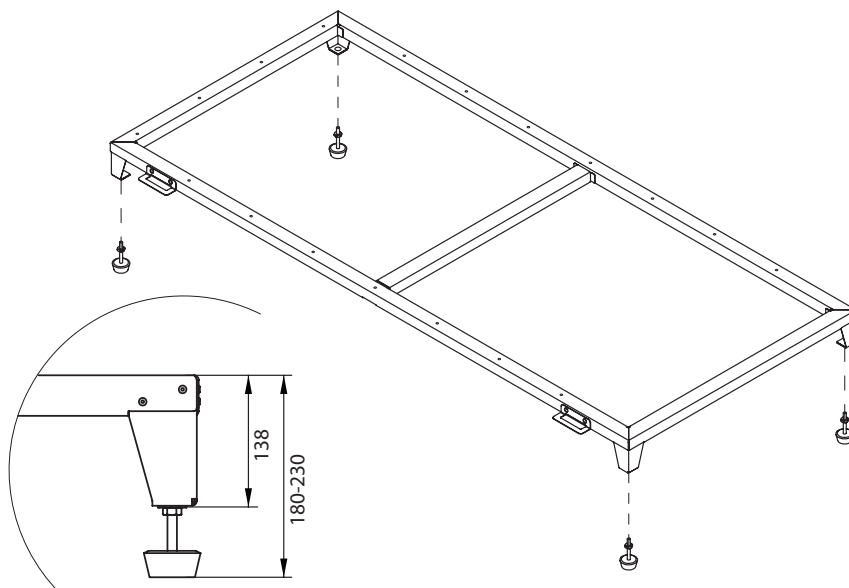

Fig. 6. Mounting frame of the unit with adjustable feet (it should be ordered separately)

Flat units are usually attached to the ceiling, floor slab or other horizontal structures with the doors down. For this purpose, their housing has special brackets with integrated vibration absorbers. The brackets should be screwed to the supporting structure of the floor slab with threaded rods or anchor bolts.

VERSO R and VERSO S units without an electric heater can also be hung on the wall or fixed to the floor. Meanwhile, units with an electric heater and units with counterflow recuperator can only be fixed to the ceiling.

| Unit | Heater type |  |  |  |  |
|------------------|-------------|---|---|---|---|
| Verso S 1300 F | HE | + | - | - | - |
| | HW | + | + | + | + |
| Verso S 2100 F | HE | + | - | - | - |
| | HW | + | + | + | + |
| Verso S 3000 F | HW | + | - | + | - |
| VERSO R 1000 FSA | HE | + | - | - | - |
| Verso R 1300 F | HE | + | - | - | - |
| | HW | + | + | + | - |
| Verso R 2000 F | HE | + | - | - | - |
| | HW | + | + | + | + |
| Verso R 3000 F | HE | + | - | - | - |
| | HW | + | + | + | + |
| Verso CF 1000 F | HE | + | - | - | - |
| | HW | + | - | - | - |
| Verso CF 1300 F | HE | + | - | - | - |
| | HW | + | - | - | - |
| Verso CF 1500 F | HE | + | - | - | - |
| | HW | + | - | - | - |
| Verso CF 2500 F | HE | + | - | - | - |
| | HW | + | - | - | - |

Fig. 7. Mounting positions of flat units



VERSO CF flat units with counterflow heat exchanger must be hung with a slope 15–20 mm on the drainage side to facilitate the discharge of condensate from the unit.

Below are the types of mounting brackets of flat units and their arrangement dimensions.

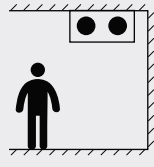
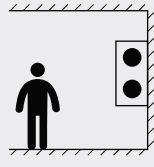
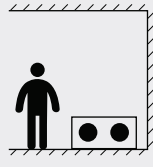
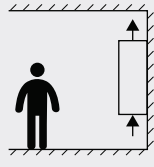
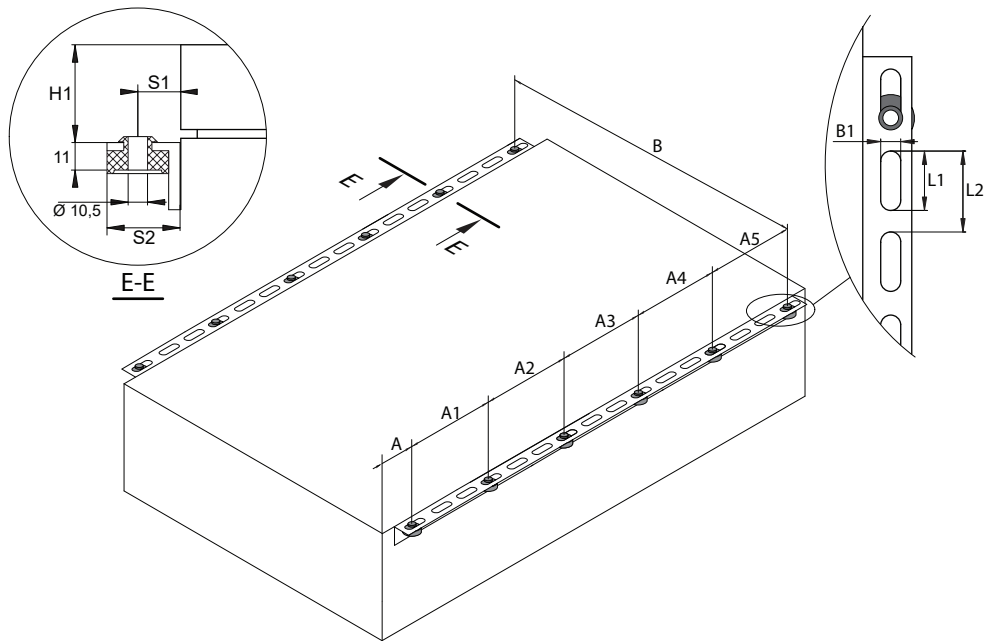

| Unit | B | A | A1 | A2 | A3 | A4 | A5 | S1 | S2 | H1 | B1 | L1 | L2 |
|-----------------|------|------|------|-----|-----|-----|-----|------|----|------|------|------|----|
| | mm | | | | | | | | | | | | |
| Verso S 2100 F | 1034 | 71,5 | 750 | - | - | - | - | 17 | 30 | 16 | 12 | 36 | 50 |
| Verso S 3000 F | 1049 | 75 | 1010 | - | - | - | - | 17 | 30 | 16 | 12 | 36 | 50 |
| Verso R 1300 F | 974 | 82 | 400 | 450 | 400 | - | - | 17 | 30 | 0 | 12 | 36 | 50 |
| Verso R 2000 F | 1244 | 91 | 400 | 400 | 280 | 400 | 400 | 17 | 30 | 49,5 | 12 | 36 | 50 |
| Verso R 3000 F | 1243 | 155 | 560 | 730 | 560 | - | - | 16 | 30 | 52 | 13,5 | 43,5 | 70 |
| Verso CF 1000 F | 1133 | 75 | 770 | 730 | - | - | - | 16,5 | 30 | 49,5 | 13,5 | 43,5 | 70 |
| Verso CF 1300 F | 1133 | 75 | 770 | 730 | - | - | - | 16,5 | 30 | 49,5 | 13,5 | 43,5 | 70 |
| Verso CF 1500 F | 1133 | 75 | 770 | 730 | - | - | - | 16,5 | 30 | 49,5 | 13,5 | 43,5 | 70 |
| Verso CF 2500 F | 2034 | 99 | 500 | 650 | 500 | - | - | 17 | 30 | 52,5 | 12 | 36 | 50 |

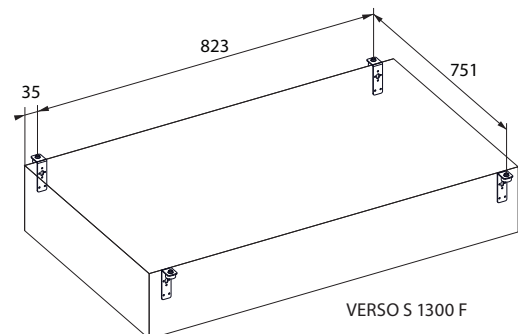
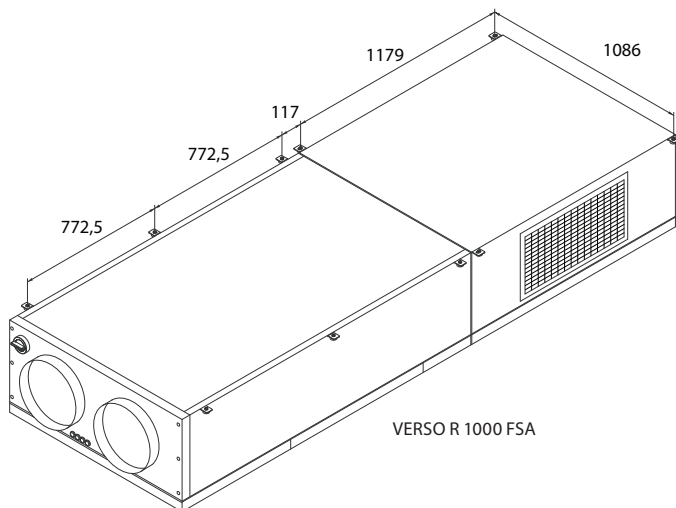

3.2. Inspection Area

Based on its type, an air handling unit may be installed indoors or outdoors. When selecting an installation or mounting location, you must foresee sufficient and security compliant access space for repair and maintenance operations. The unit must be installed in a way to allow partial or full disassembly and removal of assemblies out of the sections, if needed (e.g., in case of complex repairs).

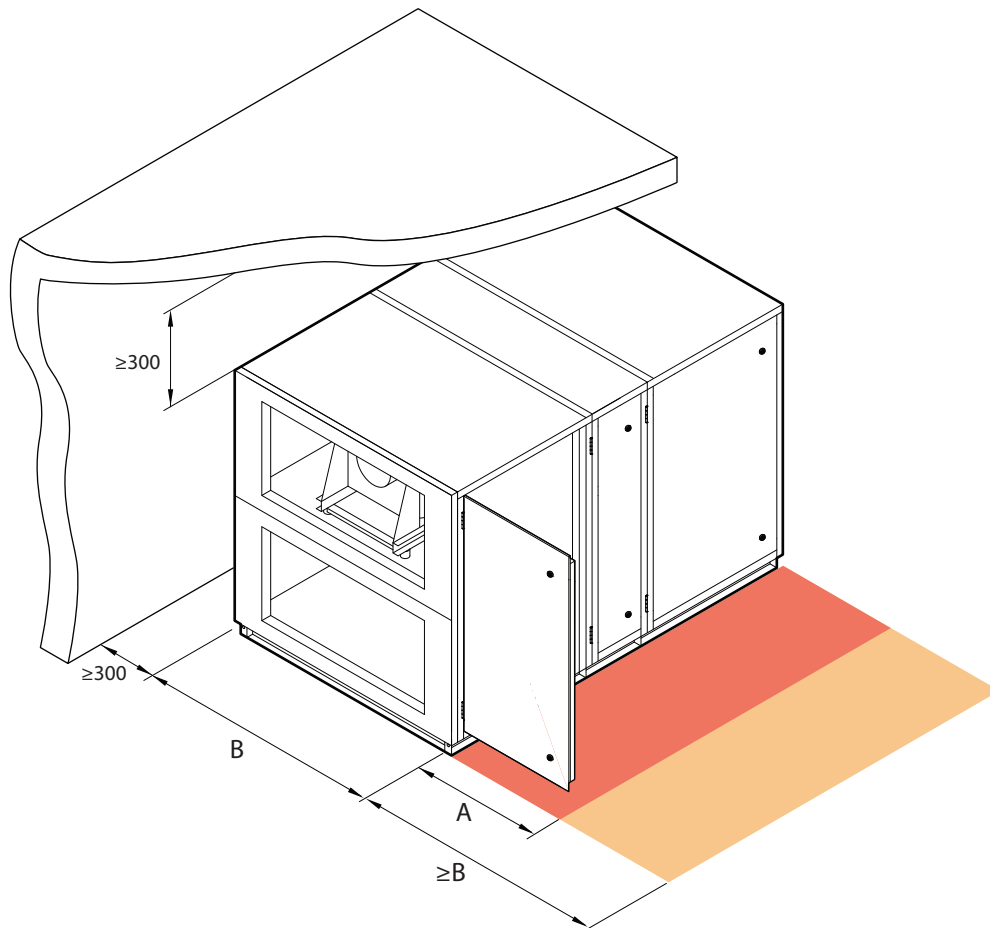

Fig. 8. Device inspection area

Minimum service area A defines an area which must be free of any stand-alone or immovable devices, equipment, partitions, structure or furniture. This area is sufficient for performing service and filter replacement works. For repair and replacement of components (e.g., removal of rotary heat exchangers), access area equal or wider to the width of the device B shall be ensured in front of the device.

| Unit | A, mm | B, mm |
|----------------|-------|-------|
| Verso R | | |
| 1000 U/H/V | 850 | 906 |
| 1300 U/H/V | | |
| 1500 U/H/V | | |
| 1700 U/H/V | 950 | 910 |
| 2000 U/H/V | | |
| 2500 H | 670 | 1000 |
| 3000 U/H/V | 800 | 1150 |
| 4000 U/H/V | | |
| 5000 V | 750 | 1405 |
| 5000 H | 800 | 1300 |
| 7000 H | 800 | 1500 |
| 7000 V | 1020 | 1505 |

| Unit | A, mm | B, mm |
|-----------------|-------|-------|
| Verso CF | | |
| 1000 U/H/V | 590 | 910 |
| 1300 U/H/V | | |
| 1700 U/H/V | | |
| 2300 U/H/V | 630 | 910 |
| 3500 U/H/V | 800 | 1150 |
| 5000 V | 710 | 1450 |

It is very important to determine a suitable place to hang flat units that attached to the ceiling. Do not hang such units above the stairs or high above, where it will not be possible to reach it without using special equipment. If the unit is hidden behind the suspended ceiling, the inspection hole (if any) must not be smaller than dimensions of the unit, or the inspection opening (if any) should not be smaller than the size of the unit, or the ceiling must be installed in such a way that it can be easily dismantled without damaging their structures. Most flat AHU's has an automation box on the side (see the "Unit components" section). All external devices and sensors are connected inside of the automation box, thus leave a space of at least 500 mm between it and the wall of the building. This will allow easier access to the electronics during installation or repair.



- It is necessary to install additional service areas for units installed high above, which would allow to work safely during technical maintenance (e.g., during filter replacement) or repair.
- When choosing a place to place or hang the unit, keep in mind that preventive maintenance should be performed at least twice a year, and sometimes more often; therefore, the user or the person responsible for the maintenance of the unit must reach it as safe and simple as possible.

3.3.Connection of Sections

Larger units of some models are assembled from separate sections (see section "Unit components") in order to transport them easier or to transfer them through the narrow openings of the building structures. Such units are usually assembled at their final installation site. Depending on whether the unit was ordered without any mounting frame, with a factory-fitted mounting frame or the one purchased separately, mounting of the sections slightly differs. Sections of the units without a mounting frame should be simply interconnected. Sections of the units with factory-made mounting frames that are designed for every section separately should be additionally tightened through the designated holes in the mounting frame (first, screw the bolts at the internal connections of the sections and only then fasten the mounting frame). If the units are mounted on a separately ordered mounting frame (see Fig. 9), their sections should be assembled and fastened together by placing them on the mounting frame and then attaching self-tapping screws to it.

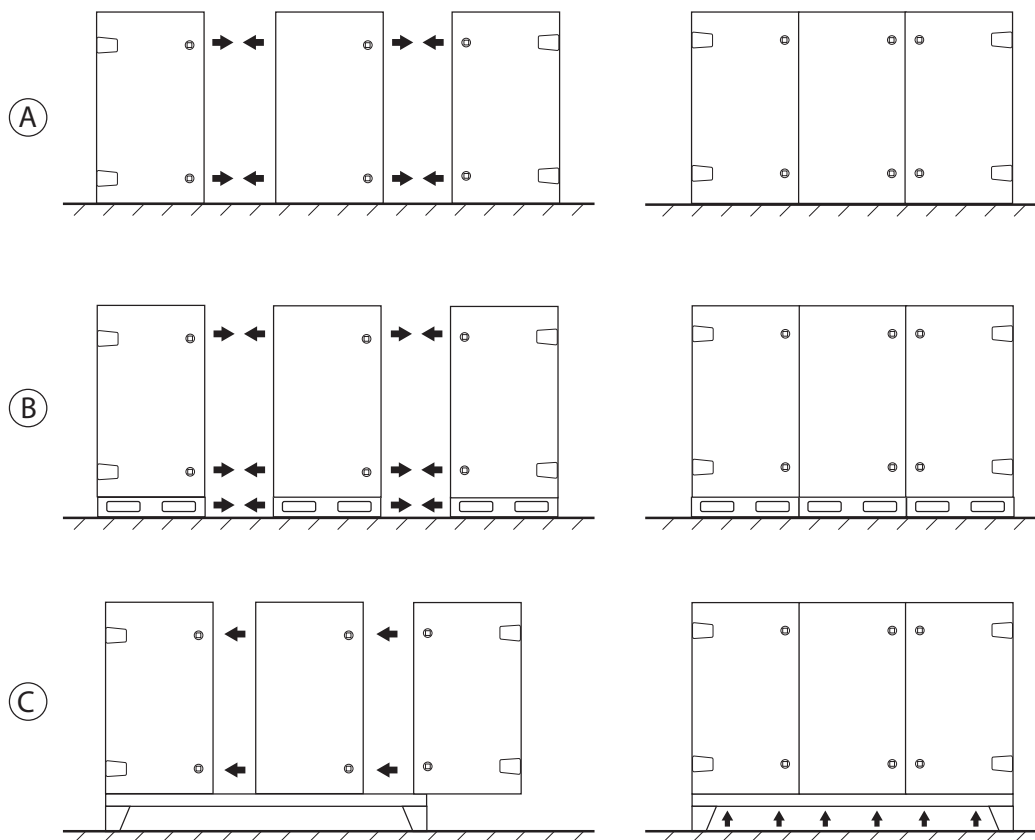

Fig. 9. Connection of sections without the mounting frame and with mounting frame
 A – without a mounting frame, B – with a factory-fitted frame for each section separately,
 C – with a mounting frame that should be ordered separately

Connect connecting cables and wires of the sections (see Chapter “Electrical Installation”) before fastening sections of an air handling unit.



- If, for any reason, sections of the unit were disassembled, before installation at it’s final location, air-tightness of the unit may differ from the data provided in documentation, unless the unit is assembled by personnel trained by the manufacturer.
- Sealing gaskets must be fitted between the sections (supplied with the unit).
- For outdoor installation, joints between the sections must be additionally sealed with silicone or other sealant.
- Drilling and using self-tapping screws on the unit casing is prohibited (in areas where it is not intended by the construction), since cables or tubes inside of the casing may be damaged.

Depending on the size of the unit, separate sections may be interconnected with external tightening elements or internal tightening brackets, using supplied screws. Sealing gaskets (supplied with the unit) must be attached to joints before joining the sections. Gaskets are installed around the entire perimeter of the section, as well as on a shelf which separates different air flows. Screws of the sections must be tightened so that the gasket is fully compressed and distance between the sections does not exceed 2–3 mm.

Sections are tightened at the inside corners, as well as in the middle at the shelf separating different air flows. If it is difficult to reach some mounting holes (e.g., near the fans or in smaller units), such sections can be easier tightened by using factory-fitted external tightening elements, which you will find at the top or back of the unit.

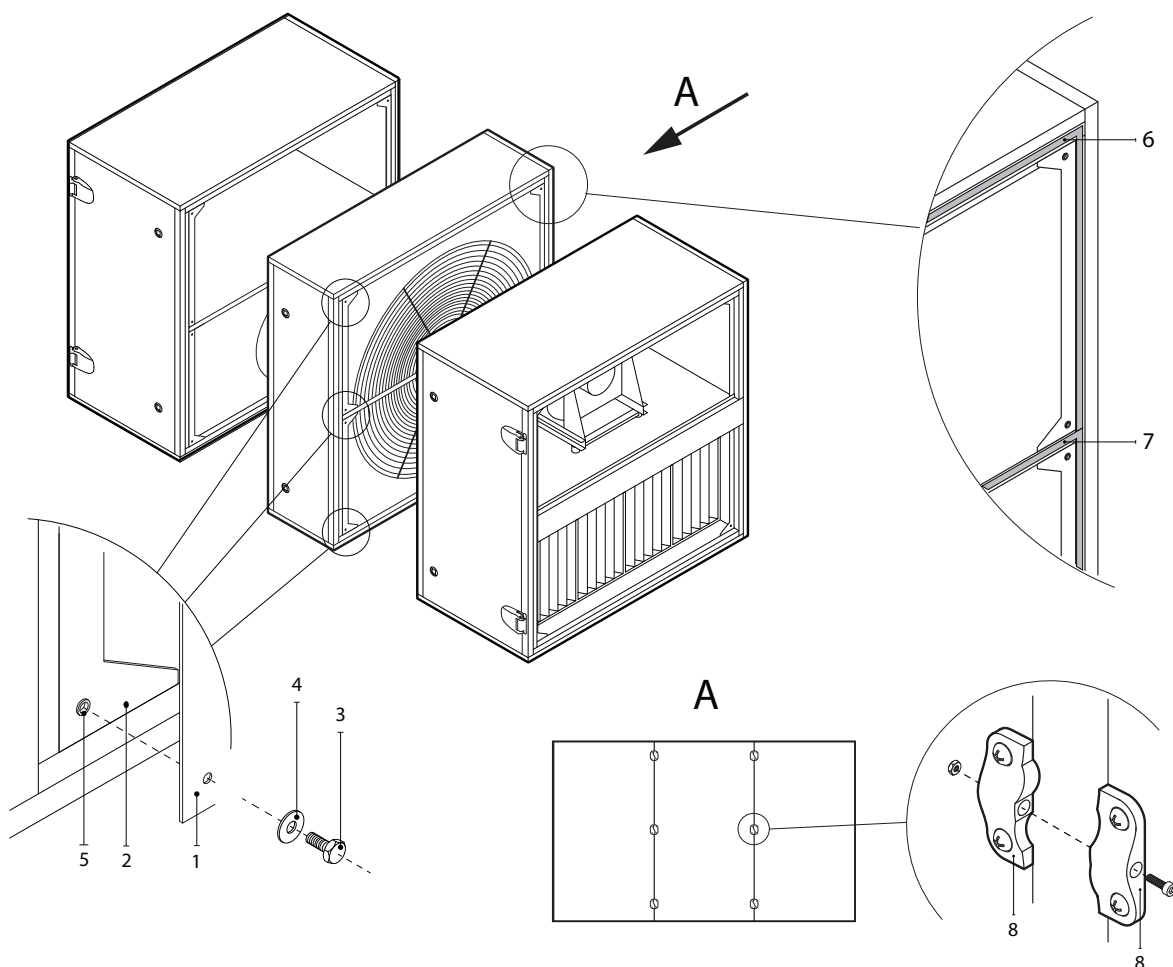
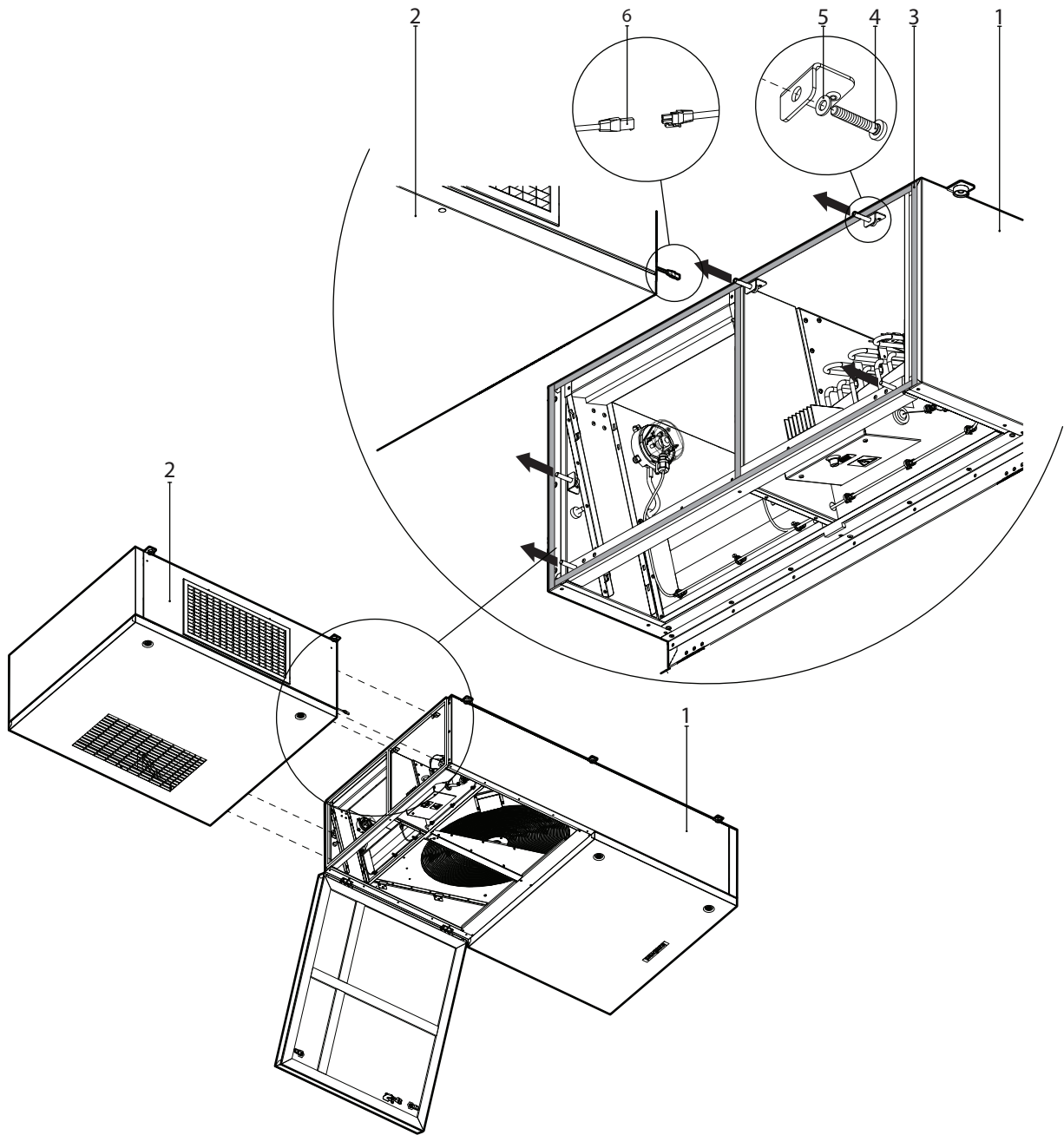

Fig. 10. Connection of sections and their sealing

1 – edge of the first section to be tightened, 2 – edge of the second section to be tightened, 3 – screw M8, 4 – washer, 5 – threaded bushing, 6 – adhesive gasket, 7 – gasket on a shelf separating different air flows, 8 – external tightening elements



- 1. Air handling unit
- 2. Noise suppressor section
- 3. Adhesive gasket
- 4. Screw M8
- 5. Washer
- 6. Supply air temperature sensor connection

Fig. 11. VERSO R 1000 FSA connection and sealing of unit sections

3.4. Duct system installation

The air in and out of the unit flows through the duct system. The duct system should be designed and selected to have low airflow rates and low pressure differentials, ensuring more accurate airflow rates, lower energy consumption, lower noise levels and longer life of the unit.

Outdoor vents must be installed as far apart as possible on different sides of the building to prevent the exhaust air from returning to the air intakes. Try to install the air intake vents where the outdoor air is the cleanest: do not direct them towards the street, car park or outdoor fireplace. We also recommend installing the air intake vent on the north or east side of the building, where the heat of the sun in summer will not have a significant effect on the supply air temperature.

It is highly recommended to install unit connecting ducts of supply inlet and exhaust outlet with a minimum slope on the outside of the premise, to avoid water flowing into the unit in case of rain or snow.

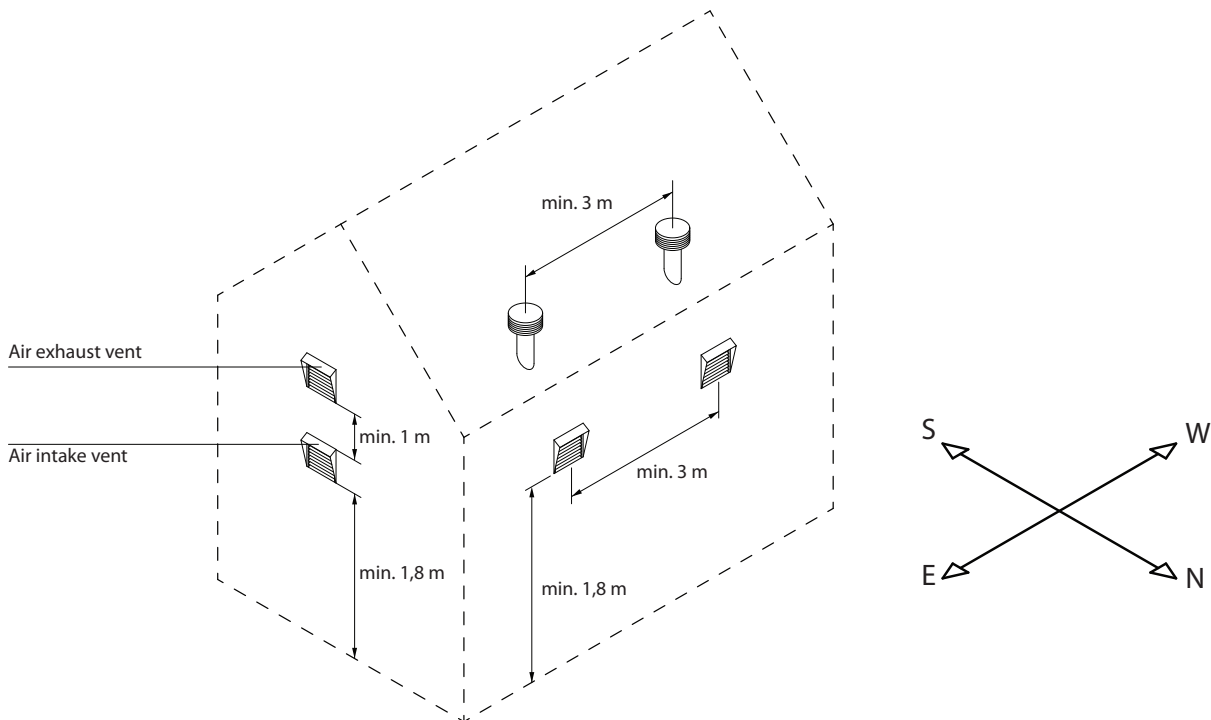

It is recommended to insulate the ducts in unheated rooms (attic, basement) to avoid heat loss. It is also recommended to insulate the supply air ducts if the unit is used for room cooling.

Circular air ducts are fitted to the unit with self tapping screws. Rectangular ducts are fitted using flange connections. Different air flow duct positions are marked on the sticker located on the AHU:

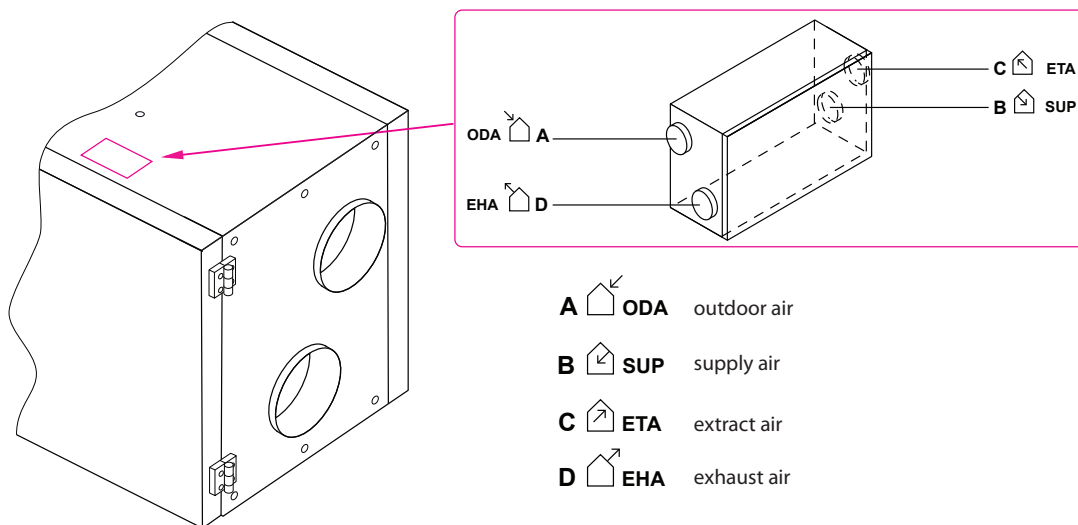



- Ducts connecting the unit to the exterior of the building must be insulated (insulation thickness 50–100 mm) to prevent condensation on cold surfaces.
- Air intake and exhaust ducts must be fitted with air closing dampers (mechanical spring-loaded or electric with actuators) to protect the unit from exposure to climatic conditions when the unit is switched off.
- In order to minimise AHU noise transferring through the ducts into ventilated areas, sound attenuators must be connected to the unit.
- Duct system elements must have separate brackets and to be mounted in a way that their weight is not shifted to the unit casing.

The diameter of the ducts varies by unit model:

| Unit | Duct diameter, mm | | | | |
|--|--------------------------|------------|------------|------------|------------|
| | Duct type | ODA | SUP | ETA | EHA |
| Verso R | | | | | |
| 1000 U/H/V 1300 U/H/V 1500 U/H/V 1300 F | Circular | 315 | 315 | 315 | 315 |
| 1000 FSA | Circular/ Rectangular | 315 | 600 × 300 | 600 × 300 | 315 |
| 1700 U/H/V 2000 U/H/V | Rectangular | 400 × 300 | 400 × 300 | 400 × 300 | 400 × 300 |
| 2000 F | Circular | 355 | 355 | 355 | 355 |
| 2500 H | Rectangular | 700 × 300 | 700 × 300 | 700 × 300 | 700 × 300 |
| 3000 U/H/V 4000 U/H/V 3000 F | Rectangular | 500 × 400 | 500 × 400 | 500 × 400 | 500 × 400 |
| 5000 V | Rectangular | 300 × 1100 | 300 × 1100 | 300 × 1100 | 300 × 1100 |
| 5000 H | Rectangular | 1000 × 500 | 1000 × 500 | 1000 × 500 | 1000 × 500 |
| 7000 H | Rectangular | 1200 × 600 | 1200 × 600 | 1200 × 600 | 1200 × 600 |
| 7000 V | Rectangular | 300 × 1200 | 300 × 1200 | 300 × 1200 | 300 × 1200 |
| Verso CF | | | | | |
| 1000 U/H/V 1000 F 1300 U/H/V 1300 F 1500 F 1700 U/H/V | Circular | 315 | 315 | 315 | 315 |
| 2300 U/H/V | Rectangular | 400 × 300 | 400 × 300 | 400 × 300 | 400 × 300 |
| 2500 F | Rectangular | 700 × 300 | 700 × 300 | 700 × 300 | 700 × 300 |
| 3500 U/H/V | Rectangular | 500 × 400 | 500 × 400 | 500 × 400 | 500 × 400 |
| 5000 V | Rectangular | 350 × 1100 | 350 × 1100 | 350 × 1100 | 350 × 1100 |
| Verso S | | | | | |
| 1300 F | Circular | 250 | 250 | – | – |
| 2100 F | Rectangular | 700 × 200 | 700 × 200 | – | – |
| 3000 F | Rectangular | 600 × 400 | 600 × 400 | – | – |

3.5. Installation of External Heating/Cooling Devices

Pipes of water heater and cooler are connected to a water mixing unit (PPU) that supplies hot/cold water from the building's water system. Heat exchangers for direct evaporation (DX) coolers/heaters are factory-filled with nitrogen gas. Before connecting a heat exchanger to a refrigerant system, nitrogen gas is discharged through a valve which is then cut off and heat exchanger connections are soldered to a pipeline. Coils for water or DX coolers are fitted with condensate trays to which a siphon and drainage piping must be connected (see Chapter "Connection of a Condensate Drain").



All connections to the heating or cooling system piping and mains must be performed by a qualified specialist.

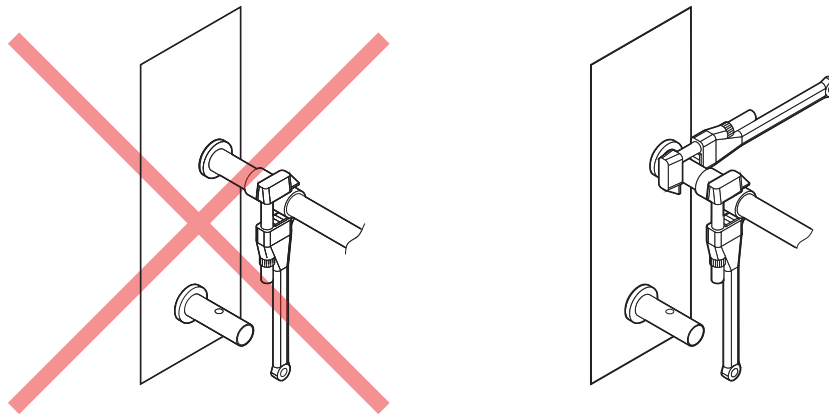

Fig. 12. Connection of sleeves

When connecting sleeves of water heaters/coolers, use two pipe wrenches to secure sleeves, otherwise they will be damaged. If water is used in the heater, for frost protection water temperature sensor (B5), must be installed and fixed with strap on the return water pipe as close to the heater as possible. Fix the sensor in a way that its metal part has good contact with a surface of the pipe. The sensor must be thermally insulated so that the room temperature does not distort water temperature measurements.

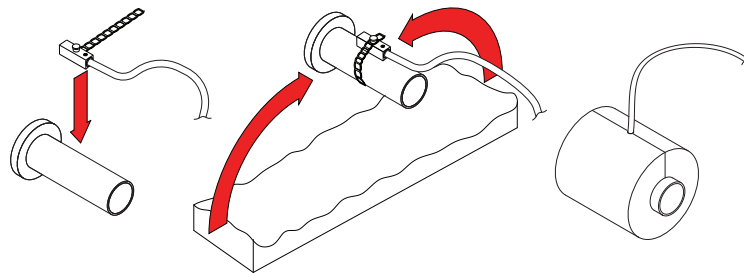

Fig. 13. Installation of a return water temperature sensor



- When operating air handling unit in temperatures lower than 0°C, it is necessary to use water-glycol mixture as a heating medium or to maintain a return water temperature of at least 25°C.
- Pipework package¹ must include circulation pump, which circulates heating/cooling medium through the coil (smaller circuit) and 3-way mixing valve with modulated actuator. In cases if 2-way valve is used, additionally it must be installed non-return valves to ensure continuous circulation around smaller circuit. PPU must be installed as close to the water coil as possible.
- In order to additionally protect the water heater from freezing, you may also use a capillary thermostat (see section "Electrical installation") that should be mounted on the surface of the heater.

¹ It is recommended to use PPU made by Komfovent.

3.6. Connection of a Condensate Drain

Operation of units with counter-flow plate heat exchangers or cooling devices causes condensation, which accumulates in specially designed condensate trays. Condensate is removed from condensate trays via drainage pipes, therefore a condensate drainage system must be connected. Drainage piping must be mounted with a slope, without narrowing sections or loops preventing water from draining. If such drainage piping is installed outdoors or in unheated premises, it must be adequately insulated or equipped with a heating cable to prevent water from freezing during winter. Drainage piping is connected to the unit with a siphon. Due to positive or negative air pressure in the air handling unit, water cannot drain out of the condensate collection tray by itself. Therefore, it is necessary to connect a proper height siphon or a siphon with a one-way valve to the drain pipe.

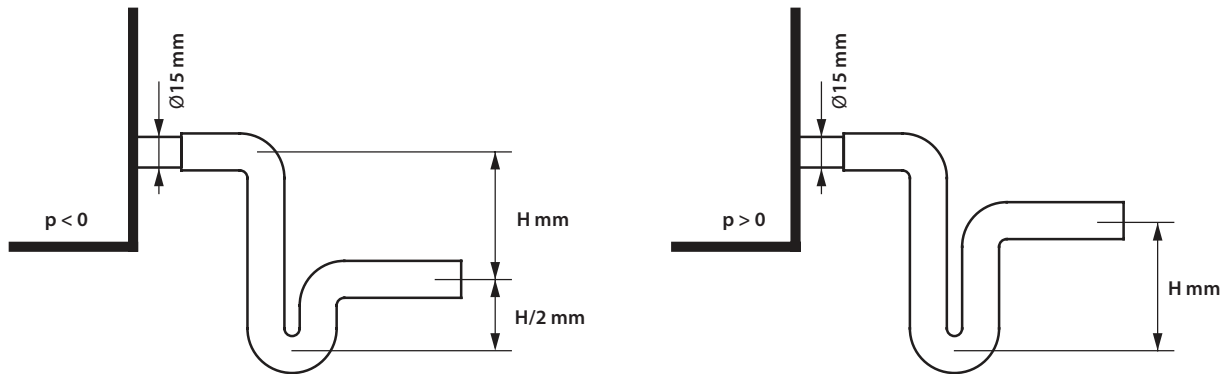

Fig. 14. Installation of a siphon

Height H of a siphon without a one-way valve is selected according to static pressure p inside the air handling unit:

$$H [\text{mm}] = 25 + p [\text{mm H}_2\text{O}] = 25 + 0.1 \times p [\text{Pa}]$$

The height of a siphon with a non-return valve may be lower; however, it depends on the technical data of the siphon used; therefore, if possible, we recommend choosing its height in the same way as for a siphon without a non-return valve.

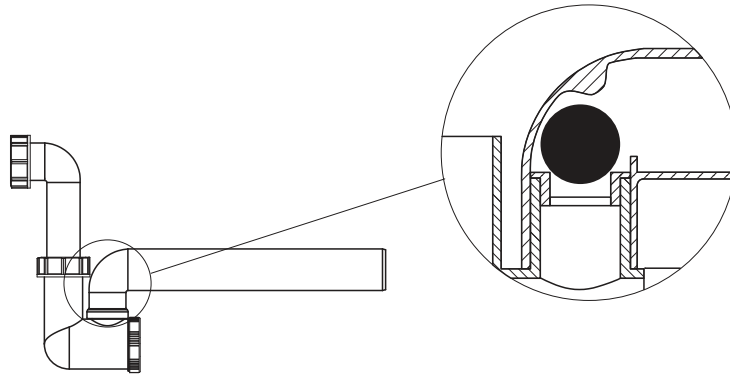

Fig. 15. Example of a siphon with a one-way valve

Any drainage system cannot be directly connected to the common waste water system in order to protect supply air from contamination with bacteria and odours. Condensate from the air handling unit drainage system shall be collected into a separate container or should be lead to a sewage grille without any direct contact: do not connect drain directly to sewer pipe and do not immerse it into water. Condensate collection location must be easily accessible for cleaning and disinfection.

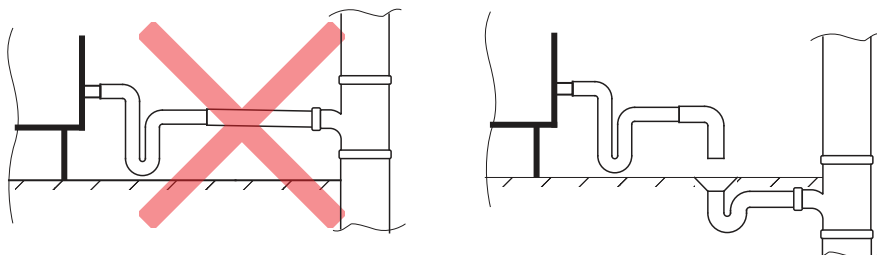

Fig. 16. Condensate drain connection to sewer system

3.7. Outdoor Units

VERSO STANDARD air handling units are not suitable to install in outdoor areas without additional modification.

Units intended to be installed outdoors, should be fixed to the base frame and air dampers must be installed on to the duct connections. AHU must be protected from the weather influence by installing dedicated roof and hoods. If possible, it is recommended to install the unit near the walls for the extra protection from the wind.

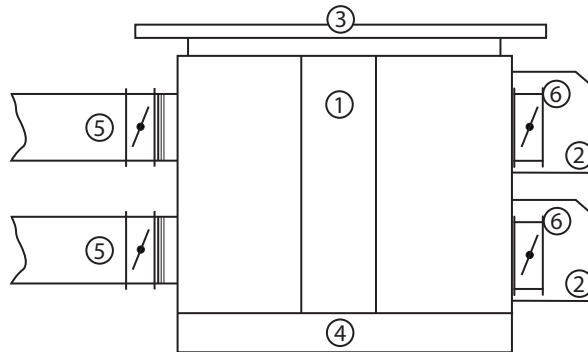

Fig. 17. Outdoor accessories
 1 – AHU, 2 – hoods, 3 – roof, 4 – base frame,
 5 – Air dampers on the room side (recommended),
 6 – Outdoor air closing dampers (mandatory)

For more information on how to install the air hoods and the roof, see section “Installation manual for outdoor accessories”.



- The outdoor units with water drainage pipes must be additionally protected against freezing, for example, with electric heating cables for drainage pipes.
- Connections of outdoor units must be additionally sealed (the sealant is not included).
- If the outdoor unit will be switched off during the cold season, supply and extract air ducts (on the indoor side) must be fitted with additional air shut-off dampers. They should prevent warm indoor air from circulating inside the unit when it is stopped to avoid condensation, which may be detrimental to electronic components.



Air intake and outlet hoods must be installed as far apart as possible (for example by installing additional duct segments between AHU and hood), to prevent the exhaust air from returning to the air intakes.



Air damper actuators of the outdoor mounted AHU must be protected from rain and snow. Actuators must be covered by installing additional protective boxes or hoods.

4. TECHNICAL INFORMATION

| Unit | Hot water | | | Electric | | | Fans input power W | Weight kg |
|-----------------|-------------------|----------------|-------------------|-------------------|----------------|-----------------|-----------------------|--------------|
| | Operating current | Supply voltage | Heater capacity | Operating current | Supply voltage | Heater capacity | | |
| | A | V | kW ¹ | A | V | kW | | |
| VERSO R | | | | | | | | |
| 1000 U/H/V | 3,3 | 1~230 | 7,0 | 7,3 | 3~400 | 3 | 2 × 180 | 196 |
| 1300 U/H/V | 5,5 | 1~230 | 10,2 | 11,7 | 3~400 | 4,5 | 2 × 270 | 203 |
| 1000 FSA | - | - | - | 7,8 | 3~400 | 3 | 2 × 123 | 238 |
| 1300 F | 6,7 | 1~230 | 8 ² | 10,7 | 3~400 | 3 | 2 × 370 | 144 |
| 1500 U/H/V | 6,7 | 1~230 | 11,7 | 12,9 | 3~400 | 4,5 | 2 × 450 | 206 |
| 1700 U/H/V | 6,7 | 1~230 | 13,8 | 12,9 | 3~400 | 4,5 | 2 × 470 | 220 |
| 2000 U/H/V | 6,3 | 1~230 | 16,4 | 16,9 | 3~400 | 7,5 | 2 × 650 | 210 |
| 2000 F | 6,3 | 1~230 | 10,5 ² | 16,8 | 3~400 | 7,5 | 2 × 670 | 280 |
| 2500 H | 8,3 | 1~230 | 13,7 ² | 18,8 | 3~400 | 7,5 | 2 × 520 | 289 |
| 3000 U/H/V | 7,1 | 3~400 | 27,7 | 19,8 | 3~400 | 9 | 2 × 850 | 456 |
| 3000 F | 7,1 | 3~400 | 16,1 ² | 19,8 | 3~400 | 9 | 2 × 720 | 289 |
| 4000 U/H/V | 9,7 | 3~400 | 28,3 | 31,1 | 3~400 | 15 | 2 × 1830 | 518 |
| 5000 V | 8,1 | 3~400 | 41,4 | 29,5 | 3~400 | 15 | 2 × 1215 | 600 |
| 5000 H | 13,1 | 3~400 | 21,4 | - | - | - | 2 × 1000 | 442 |
| 7000 H | 12,9 | 3~400 | 36 | - | - | - | 2 × 1340 | 765 |
| 7000 V | 16 | 3~400 | 46,2 | 37,7 | 3~400 | 15 | 2 × 1170 | 700 |
| VERSO CF | | | | | | | | |
| 1000 U/H/V | 3,3 | 1~230 | 9,0 | 9,5 | 3~400 | 4,5 | 2 × 178 | 269 |
| 1000 F | 3,3 | 1~230 | 5,2 | 7,3 | 3~400 | 3 | 2 × 168 | 173 |
| 1300 U/H/V | 5,5 | 1~230 | 11 | 11,7 | 3~400 | 4,5 | 2 × 370 | 225 |
| 1300 F | 5,5 | 1~230 | 7,1 | 11,7 | 3~400 | 4,5 | 2 × 360 | 175 |
| 1500 F | 6,7 | 1~230 | 7,6 | 12,9 | 3~400 | 4,5 | 2 × 460 | 190 |
| 1700 U/H/V | 6,7 | 1~230 | 11,4 | 12,9 | 3~400 | 4,5 | 2 × 465 | 243 |
| 2300 U/H/V | 6,3 | 1~230 | 13,4 | 16,8 | 3~400 | 7,5 | 2 × 660 | 250 |
| 2500 F | 6,3 | 1~230 | 13,6 | 16,9 | 3~400 | 7,5 | 2 × 640 | 340 |
| 3500 U/H/V | 6,3 | 3~400 | 18,7 | 23,4 | 3~400 | 12 | 2 × 960 | 500 |
| 5000 V | 8,3 | 3~400 | 40,6 | 29,7 | 3~400 | 15 | 2 × 1850 | 680 |
| VERSO S | | | | | | | | |
| 1300 F | 3 | 1~230 | 7,0 | 15,7 / 24,4 | 3~400 | 9 / 15 | 350 | 46 |
| 2100 F | 3,3 | 1~230 | 12,2 | 24,7 / 35,6 | 3~400 | 15 / 22,5 | 340 | 73 |
| 3000 F | 3,8 | 3~400 | 37,7 | - | - | - | 629 | 130 |

¹ Parameters of hot water 60–40°C.

² Water duct air heater (DH). It should be ordered.

5. UNIT DIMENSIONS

5.1. Horizontal units

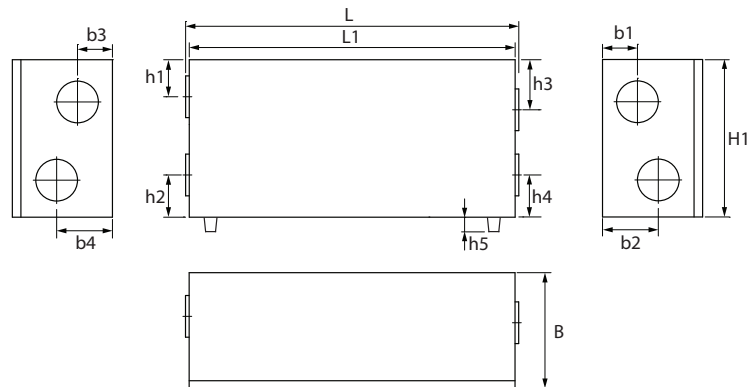

| Unit | Inspection side | Dimensions, mm | | | | | | | | | | | |
|-------------------------------------|-----------------|----------------|----------------------------|--------------|-----|-----|-----|-----|-----|-----|-----|-----|-----|
| | | Width B/B1 | Length ¹ , L/L1 | Height, H/H1 | h1 | h2 | h3 | h4 | h5 | b1 | b2 | b3 | b4 |
| VERSO R | | | | | | | | | | | | | |
| 1000 UH/H 1300 UH/H 1500 UH/H | Right R1 | 906 | 1505/1355 | 905 | 247 | 246 | 247 | 246 | - | 252 | 624 | 624 | 252 |
| | Left L1 | 906 | 1505/1355 | 905 | 247 | 246 | 247 | 246 | - | 624 | 252 | 252 | 624 |
| | Right R1 | 910 | 1547/1485 | 1000 | 270 | 270 | 270 | 270 | - | 234 | 624 | 624 | 234 |
| 1700 UH/H 2000 UH/H | Left L1 | 910 | 1547/1485 | 1000 | 270 | 270 | 270 | 270 | - | 624 | 234 | 234 | 624 |
| | Right R1 | 1000 | 1606 (618, 370, 618) | 1000 | 269 | 269 | 269 | 269 | - | 500 | 500 | 500 | 500 |
| 2500 H | Left L1 | 1000 | 1606 (618, 370, 618) | 1000 | 269 | 269 | 269 | 269 | - | 500 | 500 | 500 | 500 |
| | Right R2 | 1000 | 1606 (618, 370, 618) | 1000 | 269 | 269 | 269 | 269 | - | 500 | 500 | 500 | 500 |
| | Left L2 | 1000 | 1606 (618, 370, 618) | 1000 | 269 | 269 | 269 | 269 | - | 500 | 500 | 500 | 500 |
| | Right R1 | 1150 | 2100 (650, 700, 750) | 1150 | 303 | 303 | 303 | 303 | - | 323 | 827 | 827 | 323 |
| 3000 UH/H 4000 UH/H | Left L1 | 1150 | 2100 (650, 700, 750) | 1150 | 303 | 303 | 303 | 303 | - | 827 | 323 | 323 | 827 |
| | Right R1 | 1300 | 1872 (751, 370, 751) | 1300 | 340 | 340 | 340 | 340 | 150 | 650 | 650 | 650 | 650 |
| 5000 H | Left L1 | 1300 | 1872 (751, 370, 751) | 1300 | 340 | 340 | 340 | 340 | 150 | 650 | 650 | 650 | 650 |
| | Right R2 | 1300 | 1872 (751, 370, 751) | 1300 | 340 | 340 | 340 | 340 | 150 | 650 | 650 | 650 | 650 |
| | Left L2 | 1300 | 1872 (751, 370, 751) | 1300 | 340 | 340 | 340 | 340 | 150 | 650 | 650 | 650 | 650 |
| | Right R1 | 1500 | 1892 (751, 390, 751) | 1520 | 400 | 400 | 400 | 400 | 125 | 750 | 750 | 750 | 750 |
| 7000 H | Left L1 | 1500 | 1892 (751, 390, 751) | 1520 | 400 | 400 | 400 | 400 | 125 | 750 | 750 | 750 | 750 |
| | VERSO CF | | | | | | | | | | | | |
| 1000 UH/H 1300 UH/H 1700 UH/H | Right R1 | 910 | 1960/1810 | 905 | 242 | 242 | 242 | 242 | - | 253 | 625 | 625 | 253 |
| | Left L1 | 910 | 1960/1810 | 905 | 242 | 242 | 242 | 242 | - | 625 | 253 | 253 | 625 |
| 2300 UH/H | Right R1 | 910 | 2060/2000 | 905 | 239 | 239 | 239 | 239 | - | 250 | 648 | 648 | 250 |
| | Left L1 | 910 | 2060/2000 | 905 | 239 | 250 | 239 | 250 | - | 648 | 250 | 250 | 648 |
| 3500 UH/H | Right R1 | 1150 | 2500 | 1150 | 303 | 303 | 303 | 303 | - | 827 | 323 | 827 | 323 |
| | Left L1 | 1150 | 2500 | 1150 | 303 | 303 | | 303 | - | 827 | 323 | 827 | 323 |

¹ (L1,L2) – when the device from the sections.

5.2. Vertical units

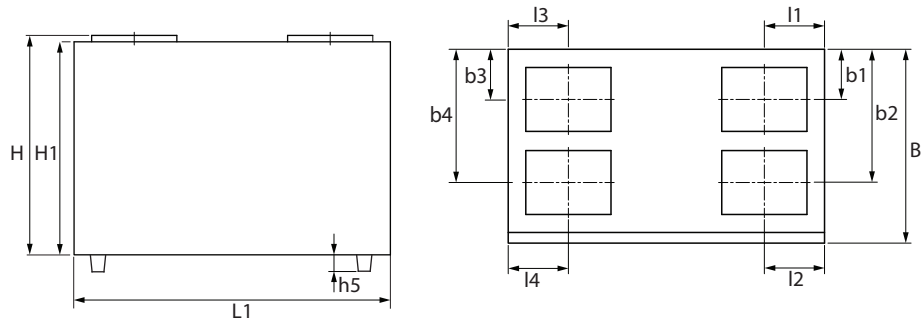

| Unit | Inspection side | Dimensions, mm | | | | | | | | | | | |
|-------------------------------------|-----------------|----------------|----------------------------|--------------|-------|-------|-------|-------|-----|-------|-------|-------|-------|
| | | Width B/B1 | Length ¹ , L/L1 | Height, H/H1 | l1 | l2 | l3 | l4 | h5 | b1 | b2 | b3 | b4 |
| VERSO R | | | | | | | | | | | | | |
| 1000 UV/V 1300 UV/V 1500 UV/V | Right R1 | 906 | 1355 | 980/905 | 250 | 250 | 250 | 250 | - | 253 | 651 | 253 | 651 |
| | Left L1 | 906 | 1355 | 980/905 | 250 | 250 | 250 | 250 | - | 253 | 651 | 253 | 651 |
| 1700 UV/V 2000 UV/V | Right R1 | 910 | 1485 | 1030/1000 | 282,5 | 282,5 | 282,5 | 282,5 | - | 235,5 | 625,5 | 235,5 | 625,5 |
| | Left L1 | 910 | 1485 | 1030/1000 | 282,5 | 282,5 | 282,5 | 282,5 | - | 235,5 | 625,5 | 235,5 | 625,5 |
| 3000 UV/V 4000 UV/V | Right R1 | 1150 | 2100 (750, 700, 650) | 1181/1150 | 328,5 | 328,5 | 328,5 | 328,5 | - | 323 | 827 | 323 | 827 |
| | Left L1 | 1150 | 2100 (750, 700, 650) | 1181/1150 | 328,5 | 328,5 | 328,5 | 328,5 | - | 323 | 827 | 323 | 827 |
| 5000 V HW/ HCW/DX 5000 V HE | Right R1 | 1405 | 1900 (700, 500, 700) | 1400 | 175 | 530 | 175 | 530 | 150 | 702,5 | 702,5 | 702,5 | 702,5 |
| | Left L1 | 1405 | 1900 (700, 500, 700) | 1400 | 175 | 530 | 175 | 530 | 150 | 702,5 | 702,5 | 702,5 | 702,5 |
| 7000 V | Right R1 | 1505 | 2204 (842,390,972) | 1533 | 246 | 646 | 245 | 645 | 150 | 750 | 750 | 750 | 750 |
| | Left L1 | 1505 | 2204 (972,390,842) | 1533 | 245 | 645 | 246 | 646 | 150 | 750 | 750 | 750 | 750 |
| VERSO CF | | | | | | | | | | | | | |
| 1000 UV/V 1300 UV/V 1700 UV/V | Right R1 | 910 | 1810 | 980/905 | 253 | 253 | 253 | 253 | - | 253 | 651 | 253 | 651 |
| | Left L1 | 910 | 1810 | 980/905 | 253 | 253 | 253 | 253 | - | 253 | 651 | 253 | 651 |
| 2300 UV/V | Right R1 | 910 | 2000 | 935/905 | 281 | 281 | 281 | 281 | - | 250 | 653 | 250 | 653 |
| | Left L1 | 910 | 2000 | 935/905 | 281 | 281 | 281 | 281 | - | 250 | 653 | 250 | 653 |
| 3500 UV/V | Right R1 | 1150 | 2500 | 1181/1150 | 329 | 329 | 329 | 329 | - | 323 | 827 | 323 | 827 |
| | Left L1 | 1150 | 2500 | 1181/1150 | 329 | 329 | 329 | 329 | - | 323 | 827 | 323 | 827 |
| 5000 V | Right R1 | 1400 | 2315 (500, 1315, 500) | 1391/1340 | 286 | 785 | 286 | 785 | 150 | 698 | 698 | 698 | 698 |
| | Left L1 | 1400 | 2315 (500, 1315, 500) | 1391/1340 | 286 | 785 | 286 | 785 | 150 | 698 | 698 | 698 | 698 |

¹ (L1,L2) – when the device from the sections.

5.3. Flat units

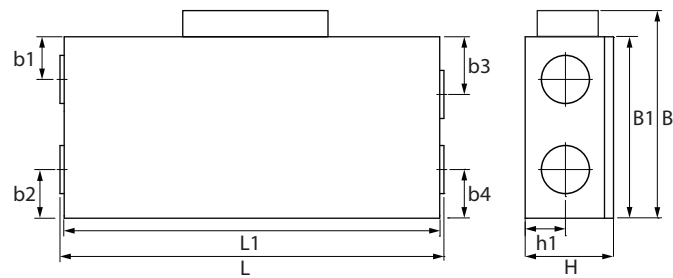

| Unit | Inspection side | Dimensions, mm | | | | | | | |
|----------------------------|-----------------|----------------|--------------|--------------|-------|-----|-----|-----|-----|
| | | B/B1 | Length, L/L1 | Height, H/H1 | h1 | b1 | b2 | b3 | b4 |
| VERSO R | | | | | | | | | |
| 1300 F | Right R2/L1 | 1050/940 | 1510/1360 | 480 | 220 | 250 | 245 | 250 | 245 |
| | Left L2/R1 | 1050/940 | 1510/1360 | 480 | 220 | 250 | 245 | 250 | 245 |
| 2000 F | Right R2/L1 | 1318/1210 | 2203/2060 | 527 | 263 | 305 | 305 | 305 | 305 |
| | Left L2/R1 | 1318/1210 | 2203/2060 | 527 | 263 | 305 | 305 | 305 | 305 |
| 3000 F | Right R2/L1 | 1318/1210 | 2220/2160 | 648 | 324 | 303 | 303 | 303 | 303 |
| | Left L2/R1 | 1318/1210 | 2220/2160 | 648 | 324 | 303 | 303 | 303 | 303 |
| VERSO CF | | | | | | | | | |
| 1000 F 1300 F 1500 F | Right R2/L1 | 1210/1100 | 1795/1650 | 527 | 263 | 275 | 275 | 275 | 275 |
| | Left L2/R1 | 1210/1100 | 1795/1650 | 527 | 263 | 275 | 275 | 275 | 275 |
| 2500 F | Right R2/L1 | 2045/2000 | 1910/1850 | 528 | 263,5 | 500 | 500 | 500 | 500 |
| | Left L2/R1 | 2045/2000 | 1910/1850 | 528 | 263,5 | 500 | 500 | 500 | 500 |

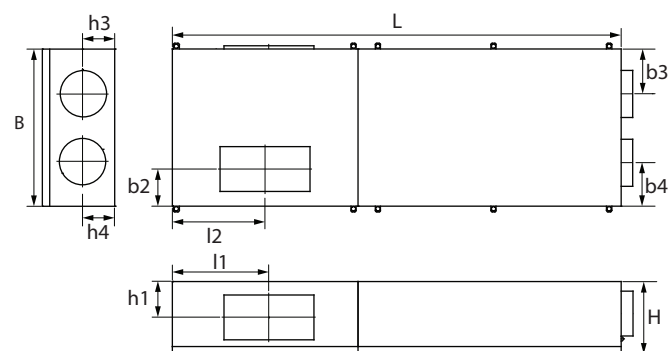

| Unit | Inspection side | Dimensions, mm | | | | | | | | | | |
|----------------|-----------------|----------------|-----------|-----------|------|------|-----|-------|-------|-----|-----|-----|
| | | Width, B | Length, L | Height, H | l1 | l2 | b2 | b3 | b4 | h1 | h3 | h4 |
| VERSO R | | | | | | | | | | | | |
| 1000 FSA | Right R1 | 1050 | 3000 | 490 | 2379 | 2380 | 248 | 302,5 | 302,5 | 240 | 216 | 216 |
| | Left L1 | 1050 | 3000 | 490 | 621 | 620 | 248 | 302,5 | 302,5 | 240 | 216 | 216 |

5.4. Units VERSO S

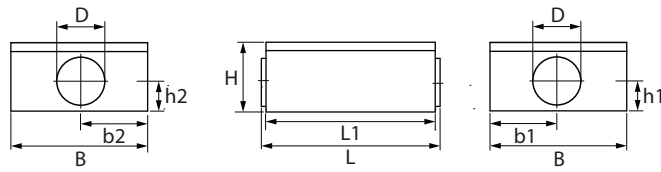

| Unit | Dimensions, mm | | | | | | |
|----------------|----------------|--------------|--------------|-----|-----|-------|-------|
| | B/B1 | Length, L/L1 | Height, H/H1 | h1 | h2 | b1 | b2 |
| VERSO S | | | | | | | |
| 1300 F | 700 | 925/893 | 350 | 152 | 152 | 350 | 350 |
| 2100 F | 1000 | 953/893 | 350 | 152 | 152 | 500 | 500 |
| 3000 F | 1015 | 1227/1160 | 555 | 250 | 250 | 507,5 | 357,5 |

6. ELECTRICAL INSTALLATION

Only qualified professionals may perform electrical installation works in accordance with the manufacturer's instructions and applicable legal acts and safety requirements. Before installation of any electrical components:



- Make sure the unit is unplugged from the mains.
- If the unit has been standing in an unheated room for a long time, make sure there is no condensation inside and check if contacts and electronic parts of the connectors are not damaged by moisture.
- Inspect the power cable and other wiring for damage in insulation.
- Locate the wiring diagram for your unit according to the unit type.

6.1. Requirements for Electrical Connection



- Connect the unit only to a proper power outlet with protective earthing. Earthing must be installed according to the EN61557, BS 7671 requirements.
- It is recommended to connect AHU to the mains via automatic circuit breaker with 30 mA current leakage protection (type B or B+).
- Control cables should be installed at least 20 cm away from power cables to reduce the possibility of electrical interference.
- All external electrical elements must be connected strictly according to the wiring diagram of the unit.
- Do not disconnect the connectors by pulling wires or cables.

Lead-in cable diameter depends on a maximum current specified in the technical data print-out of the specific unit.

| Current, A | Cable type |
|------------|-------------------------------|
| 15 | 5 × 1,5 mm ² (Cu) |
| 21 | 5 × 2,5 mm ² (Cu) |
| 27 | 5 × 4,0 mm ² (Cu) |
| 34 | 5 × 6,0 mm ² (Cu) |
| 50 | 5 × 10,0 mm ² (Cu) |
| 70 | 5 × 16,0 mm ² (Cu) |
| 85 | 5 × 25,0 mm ² (Cu) |

6.2. Connection of Electrical Components

All internal and external elements of the unit are connected to the main board of the C5 control panel (marked as “RG1” in wiring diagrams), located inside the unit. In some units, you will need to unscrew the metal cover to access the control panel. You can see the exact location of the C5 control panel in the unit in section “Unit components”.

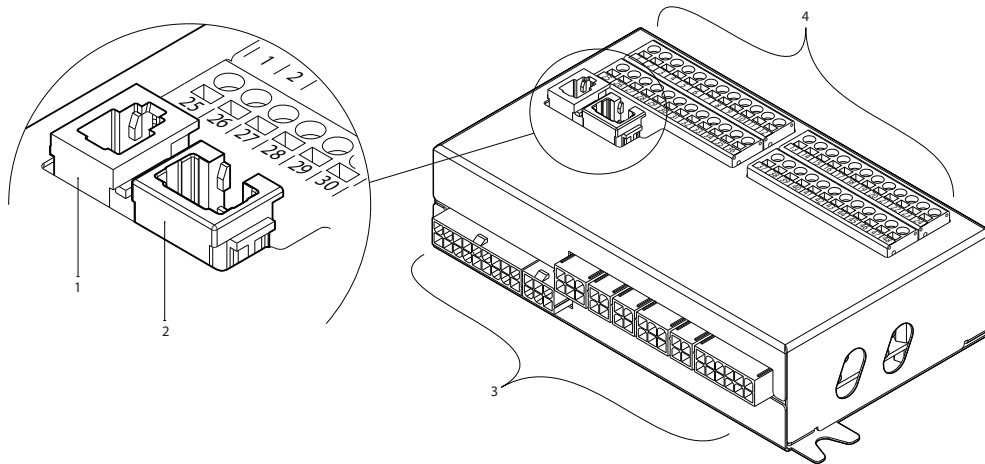

Fig. 18. C5 controller main board

1 – control panel connection, 2 – Intranet or Internet connection, 3 – inner connections of components, 4 – terminals for external components

Terminals for the external elements of the controller board are numbered and are used only to connect external components. These may remain empty if no additional features are required.

| | | | | | | | | | |
|---------|-------|---|------------|-----|----|--------|---------------------------------|---|-----|
| INPUTS | B9 | Humidity sensor | 0..10V | 25 | 1 | B | MODBUS RS485 interface | OUTPUT | |
| | | | ~24V | 26 | 2 | A | | | |
| | | | N | 27 | 3 | GND | | | |
| | B8 | Air quality sensor | 0..10V | 28 | 4 | IN4 | External control | INPUTS | |
| | | | ~24V | 29 | 5 | IN3 | | | |
| | | | N | 30 | 6 | IN2 | | | |
| | B7 | Exhaust air pressure sensor | 0..10V | 31 | 7 | IN1 | External control | INPUTS | |
| | | | ~24V | 32 | 8 | C | | | |
| | | | N | 33 | 9 | | | | |
| | B6 | Supply air pressure sensor | 0..10V | 34 | 10 | NTC | Return water temperature sensor | B5 | |
| | | | ~24V | 35 | 11 | | | | |
| | | | N | 36 | 12 | NTC | Supply air temperature sensor | B1 | |
| OUTPUTS | FG1 | Air damper actuator | 0..10V | 37 | 13 | 0..10V | Humidifier control | TG3 | |
| | | | ~24V | 38 | 14 | GND | | | |
| | | | N | 39 | 15 | | | | |
| | DX | Operation Alarm Common | Indication | NO | 40 | 16 | 0..10V | Cold water mixing valve / DX capacity control | TG2 |
| | | | | NO | 41 | 17 | ~24V | | |
| | | | | C | 42 | 18 | N | | |
| | DX | DX3 / Heating DX2 / Cooling DX1 / Start Common | | NO | 43 | 19 | 0..10V | Heating damper actuator | TG1 |
| | | | | NO | 44 | 20 | ~24V | | |
| | | | | NO | 45 | 21 | N | | |
| | INPUT | Water pump/ coil alarm | | DIN | 47 | 23 | L | Water pump for cooling 230V AC, 1A | S2 |
| | | | | GND | 48 | 24 | N | | |
| | | | | | | | | | |

Fig. 19. Connection terminals for external components on the C5 main board



Total power of all external devices with 24 V supply voltage shall not exceed 25 W.

Modbus RS485 (1-3) – data cable connection for controlling the unit from a building management system via Modbus RTU protocol. Also these terminals can be used for additional heating/cooling zone control module connection (see „Additional zone control installation manual“).

External control (4–8) – terminals for controlling specific functions of the unit via external contacts which are connected to a common terminal 8. These include thermostats, switches, motion sensors and other devices with normally open or closed contacts. Activated functions will operate as long as those contacts are connected.

- **Terminal 4** is used to switch between heating and cooling modes, if a combined water heater is used (after terminals are connected, the water valve actuator and pump will be controlled according to the cooling signal. For example, a thermostat can be connected here to close terminals when cold water circulates in the system).
- Closing contacts **5** and **8** will stop the unit.
- Fire alarm requires a normally closed contact (NC), therefore, a jumper is connected between **terminals 6 and 8**, instead of which, building fire system can be connected. When the contact is disconnected, the unit stops or fans speed up (according to the order) and a fire alarm message is displayed.
- **Terminal 7** activates an “Override” ventilation mode (OVR). This mode has priority over other AHU functions and may be activated even when the unit is stopped (i.e. to start the unit by closing contacts). OVR function settings are set via the control panel or computer. This function is active as long as terminals are closed.

B5 (9–10) – when a water heater is installed, this terminal is used for connecting a return water temperature sensor (NTC 10k Ω) which protects against freezing.

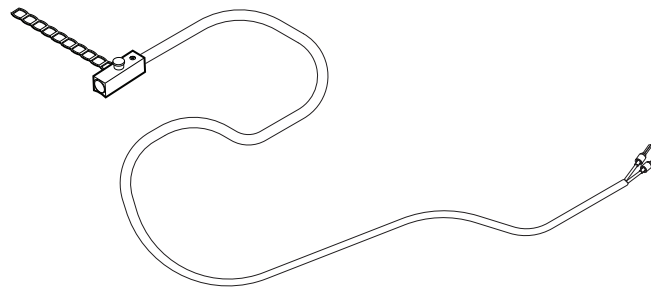

Fig. 20. Return water temperature sensor

B1 (11–12) – terminal for a supply air temperature sensor (NTC 10k Ω) for controlling air temperature.

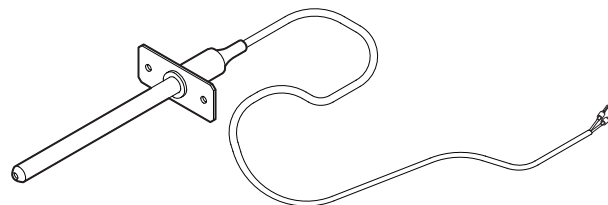

Fig. 21. Supply air temperature sensor

For the most accurate temperature measurement, sensor in a duct must be installed after all heating/cooling devices at least two duct diameters away from the nearest coil.

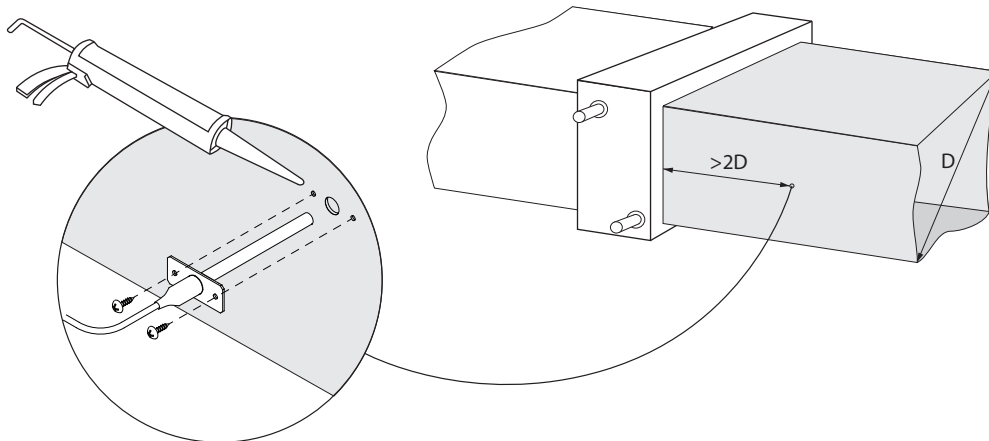

Fig. 22. Installation of a supply air temperature sensor

TG3 (13–14) – for connecting control signal (0..10 V) of an external humidifier or dehumidifier, if activated.

TG2 (15–17) – power supply (24 V AC) and control signal (0..10 V) for a water cooler mixing valve actuator. If a DX unit is installed (controlled by a modulated signal), DX unit control signal is connected to these terminals and water cooling is disabled.

TG1 (18–20) – power supply (24 V AC) and control signal (0..10 V) for a water heater mixing valve actuator. If a combined water heater/cooler is used, valve actuator will be controlled by a heating or cooling signal (whichever is supplied).

S2 (21–22) – 230 V AC supply voltage for a cold water circulation pump, which is used with external water cooler coil and is activated when cooling is needed. Max 1 A.

S1 (23–24) – 230 V AC supply voltage for a hot water circulation pump, which is used with external water heater coil and is activated when heating is needed. Max 1 A.

B8/B9 (25–30) – terminals for air quality and humidity sensors, which are used for the following functions (see “User Manual”):

- Air quality control (AQC).
- Operation on demand (OOD).
- Humidity control (HUM).

These functions may be controlled via the following type sensors (sensor type may be changed only by an authorised service representative):

- Carbon dioxide CO₂ (default setting) – range 0..2000 ppm.
- Air quality VOC (*Volatile organic compound*) – range 0..100%.
- Relative humidity RH – range 0..100% RH.
- Temperature TMP – range 0..50°C.

B6/B7 (31–36) – when a VAV airflow control method is used (see “User Manual”), optional pressure sensors must be installed and connected in the ducts. Follow the manufacturer’s instructions for installation of VAV pressure sensors. Also, these terminals are used for DCV airflow control when a separate 0...10 V signal can be used to adjust the ventilation intensity (see “User Manual”).

FG1 (37–39) – terminals used to connect air damper actuators. These terminals may also be used for connecting 24 V AC power supply actuators with or without a spring return.

Indication (40–42) – terminals are used when a normally open (NO) contact is necessary for operation status or fault indication.

Cooling control (43–46) – digital normally open (NO) outputs for controlling direct expansion (DX) coolers/heaters. The purpose of outputs differs depending on the type of DX device control ordered or programmed in the control panel¹:

- Stepping control of start/stop type DX cooling devices – each of the 3 outputs is activated one after the other, when the power of the previous stage is insufficient, with 5 min. delay.
- Stepping control of start/stop type reversible (cooling/heating) DX devices – DX1 and DX2 outputs are activated one after the other, when the power of the previous stage is insufficient, with 5 min. delay. DX3 output is used for switching DX devices between cooling and heating modes.

¹ If the DX device was not predefined in the controller software, these outputs will be inactive.

- If a DX device is controlled by a modulated signal (0..10 V), digital outputs are used for starting a DX unit and changing operation modes thereof: DX1 – start signal, DX2 – cooling, DX3 – heating. Power control signal for this type of the DX unit is connected to TG2 terminals.

Water pump/coil alarm (47–48) – here you can connect signal for indication of water pump faults (if this function is available on the pump); if the pump fails, the air handling unit is stopped. Also these terminals can be used for additional frost protection of water heater coil, by connecting here capillary thermostat, which is mounted on the surface of the coil.

All wires to be connected to the main controller board shall be pulled through grommets (top or side of the air handling unit). Grommets are fastened to ensure tightness.

6.3. Control Panel Installation

The control panel must be installed in a room with:

- Ambient temperature – 0..40°C;
- Relative humidity – 20..80%;
- Guaranteed protection against accidental water drops.

Control panel can be mounted in a concealed mounting box or directly on the wall (screws supplied with the panel). You can also use magnets (on the back surface) to attach the panel to metal surfaces (i.e. on the door of the unit).



Do not use any other type or size screws but those that are supplied for control panel mounting. Wrong screws may cause damage to a circuit board.

Remote controller is supplied with a 10 m cable. If this cable is too short, you can replace it with a 4 × 0.22 mm cable, up to 150 m long.

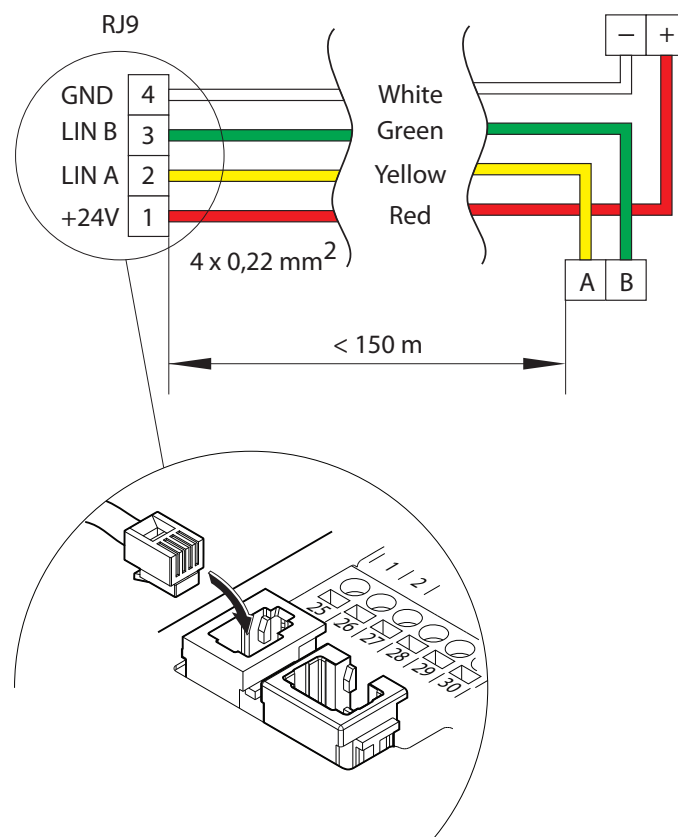

Fig. 23. Control panel wiring diagram

Control panel cable shall be installed further away from other power supply cables or high voltage electrical equipment (electrical enclosure, electrical water heating boiler, air conditioning unit, etc.). The cable can be pulled through openings in the back or bottom part of the control panel (follow the installation instructions provided with the control panel). Cable to the C5 control board must be connected to a dedicated slot (see Fig. 23).

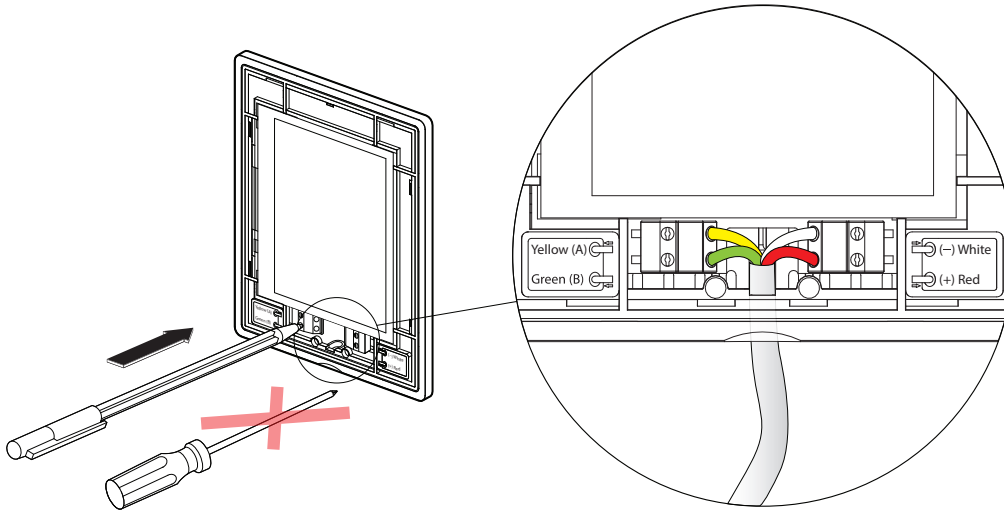

Fig. 24. Control panel cable wiring



Do not use sharp tools for pinning contacts in the control panel (e.g., screwdriver). Please use a pencil or a ballpoint pen.

6.4. Connection of Cables and Wires Between Sections

Before fastening sections of the larger air handling units together, you shall connect connecting cables and wires in between of the sections. Cable connectors are labelled with connector numbers; only connect connectors with the same number. Number of cables and connectors in different sections may differ depending on fitted components. If any features or external components are not ordered, there may be some uncoupled connections between the sections. Refer to the wiring diagram of the specific unit to see what connections should be used.

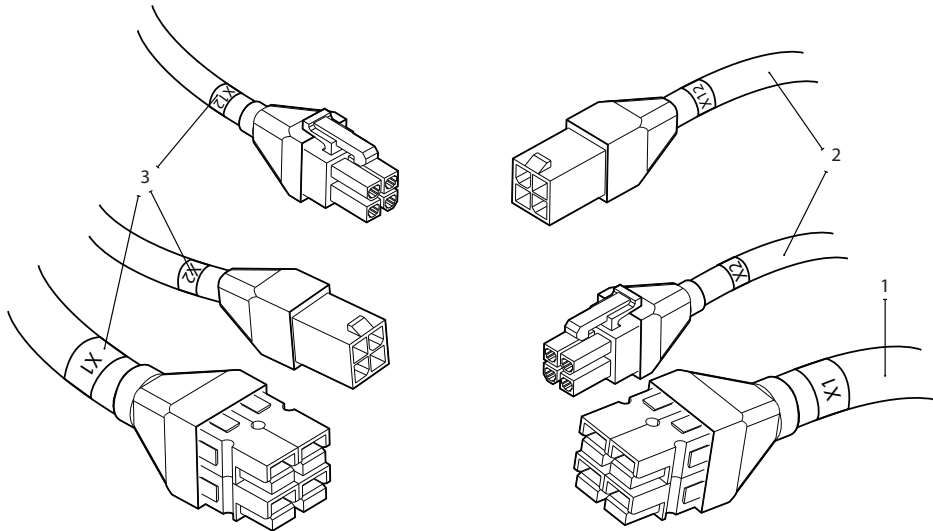

Fig. 25. Cable connections between sections

1 – power supply cable, 2 – communication cables between circuit boards 3 – labels with connection numbers



Connected wires and cables must be inspected to ensure that they will not accidentally disconnect due to vibrations of the unit or get in contact with moving parts of the unit (fans, valves, rotor wheel). If necessary, use special ties to attach the wires to the unit housing.

6.5. Connecting the Unit to the Internal Computer Network or the Internet

Your AHU may be controlled not only with a control panel, but also with a computer or smart phone. For this reason the unit must be connected to the internal computer network or the Internet. In case of a computer, the unit is controlled via a web browser, and in case of a smart phone - via the Komfovent app. Use CAT5 type cable to connect your AHU to the computer network (RJ45 connection; see Fig. 18). The total cable length between the unit and the network router must not exceed 100 metres. By default, the IP address of your air handling unit is **192.168.0.50**, however it can be changed (if necessary) according to the local network parameters. IP address can be found and changed in the control panel.

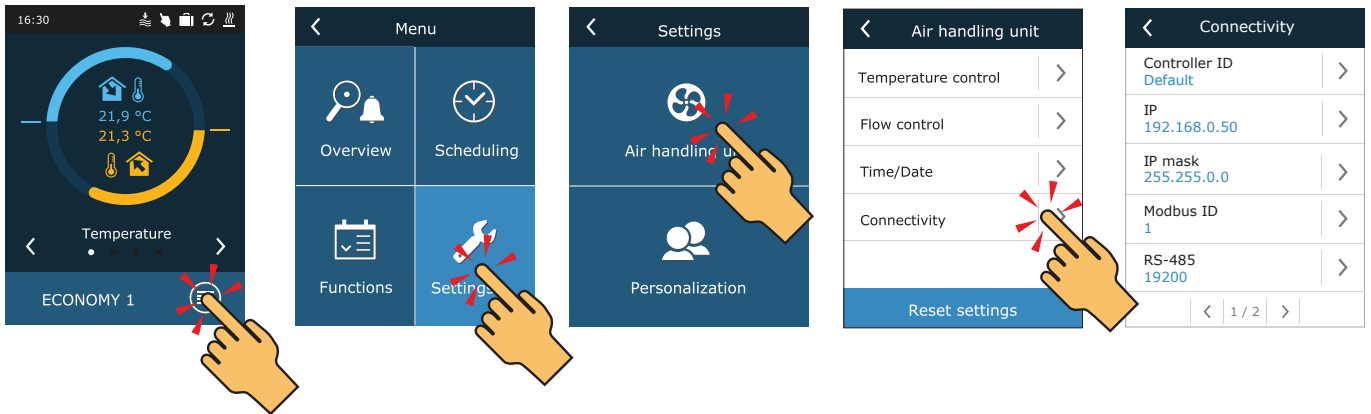

Fig. 26. Viewing and changing the IP address with a control panel

An air handling unit connected to a network router can be controlled by a computer via wireless connection (Wi-Fi). The unit may also be controlled wirelessly in a local network using a smart phone with the Komfovent app. Once the unit is connected to the network router, you should assign a free IP address on the local network.

When connecting your computer directly to the unit, open the network settings and manually assign an IP address, the last number of which would be different from the unit's IP address (for example, if the unit's IP address is 192.168.0.50, assign the address 192.168.0.70 to the computer). Enter the subnet mask: 255.255.0.0.

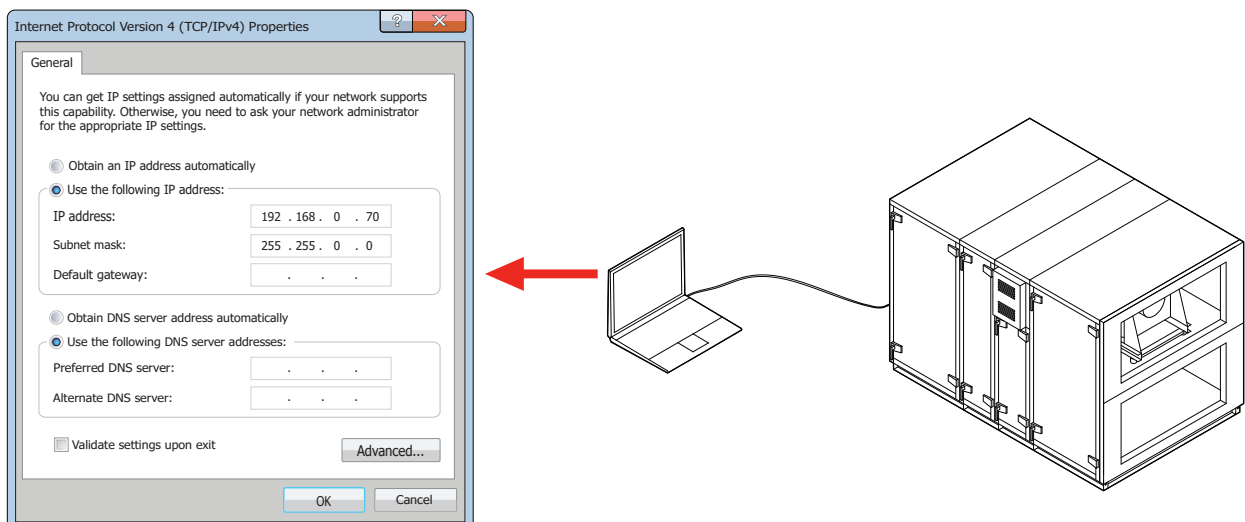
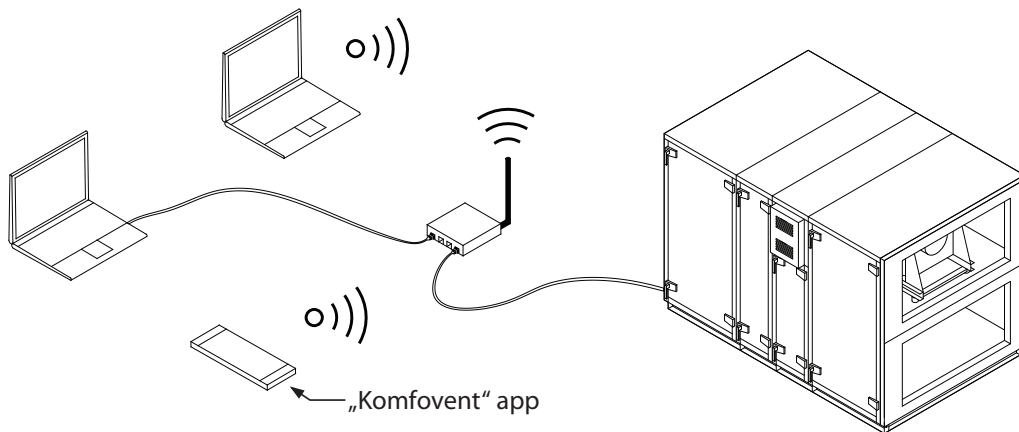

Fig. 27. Computer network settings for direct connection to the unit

In order to control your AHU over the Internet, connect it to the network router which has access to the Internet. Follow the router manual to configure port forwarding to the unit IP address. Depending on whether you will use your computer or smart phone with the Komfovent app to control your AHU, you will also need to enter a corresponding port number to the router. For control via your computer use the port **80**, and for control via your smart phone use the port **502**. Once a computer or smart phone is connected to the Internet, enter an external router IP address and set port number to your web browser or the Komfovent app to access the AHU user interface (for more information on control with a computer or smart phone see "User Manual").

Connection to the local computer network



Connection via the Internet

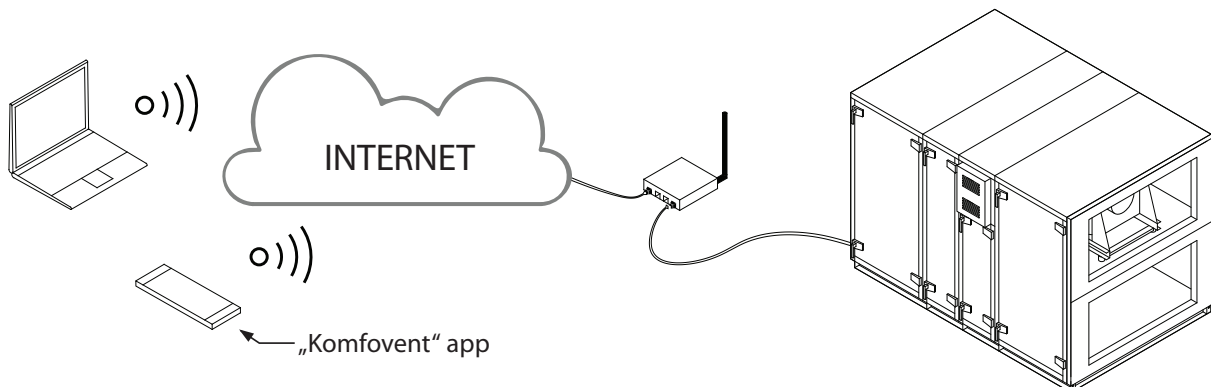

Fig. 28. Examples for the AHU connection to the Internet or the local network

7. FILTERS

Air filters are intended for removing dust, bacteria and other fine particles from the supplied and extracted air. Most VERSO STANDARD air handling units are fitted with compact filters or pocket filters in larger units. Filters are made of synthetic fabric and can have different filtration classes¹, i.e., intended for removing particles of different sizes. In general, supply air flow is equipped with better filtering class filters than extracted air since the cleaned outdoor air is supplied to the premises.

The contamination of the filters is monitored by pressure switches installed inside the unit and set to a certain differential pressure, based on the type of filter used. If filters of other manufacturer or different filtration class is used, the range of the pressure switches must be set correctly after their replacement. The pressure switches are set by removing the top cover and turning the knob to the necessary limit of differential pressure. After the filter becomes dirty and the differential pressure value is reached, a message will be displayed on the control panel or computer screen.

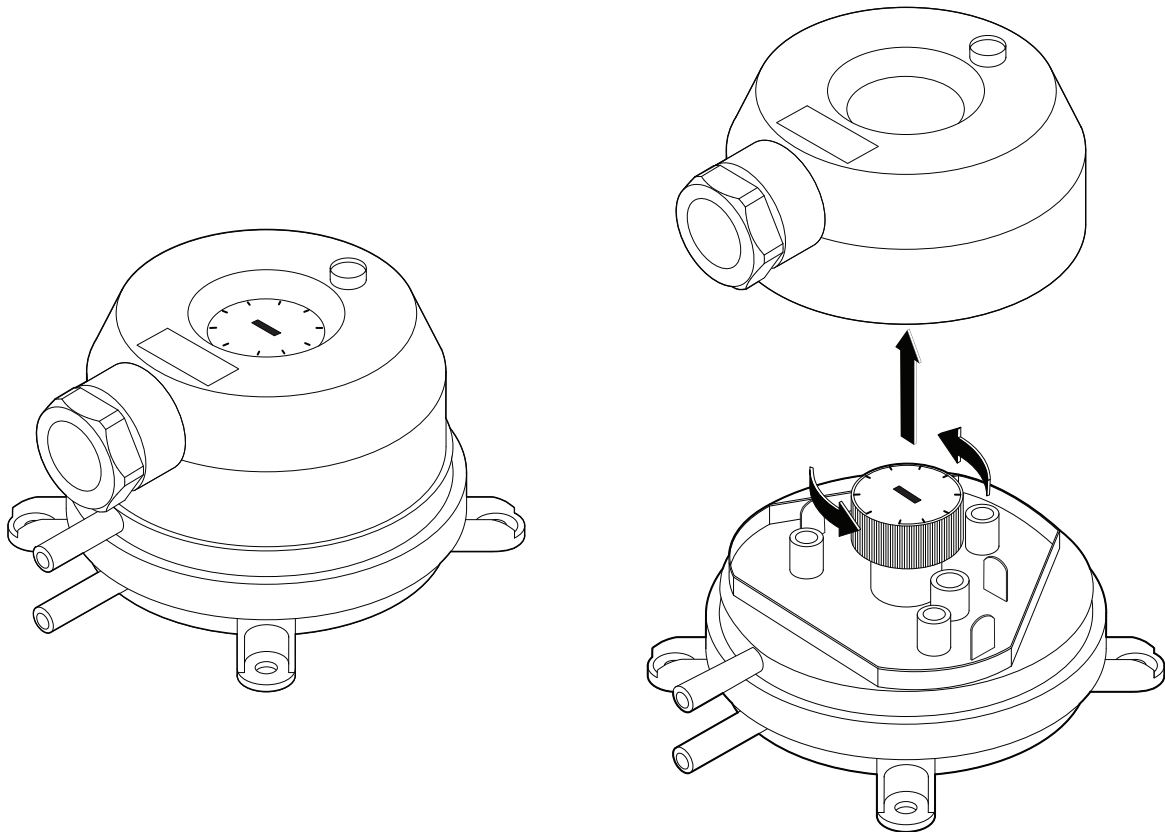

Fig. 29. Pressure switch

¹ Depends on the order.

Filters are removed/inserted one by one (depending on the size of the unit, several filters may be used). For filters of some sizes, an additional sealing gasket must be placed on the edge of the frame to prevent gaps between them and the housing of the unit. When inserting filters into the hanging flat units, be careful not to drop the filters or damage them when closing the door. If bag filters are used in the unit, they should be fixed with a special clamping mechanism. In order to replace the bag filters, they must be released by pulling the handles of the clamping mechanism at the top and bottom of the filter (see Annex 1 "Filter replacement" of VERSO STANDARD user manual). After inserting the bag filters, don't forget to push the clamping mechanism properly to press the filters tightly to the designated gaskets.

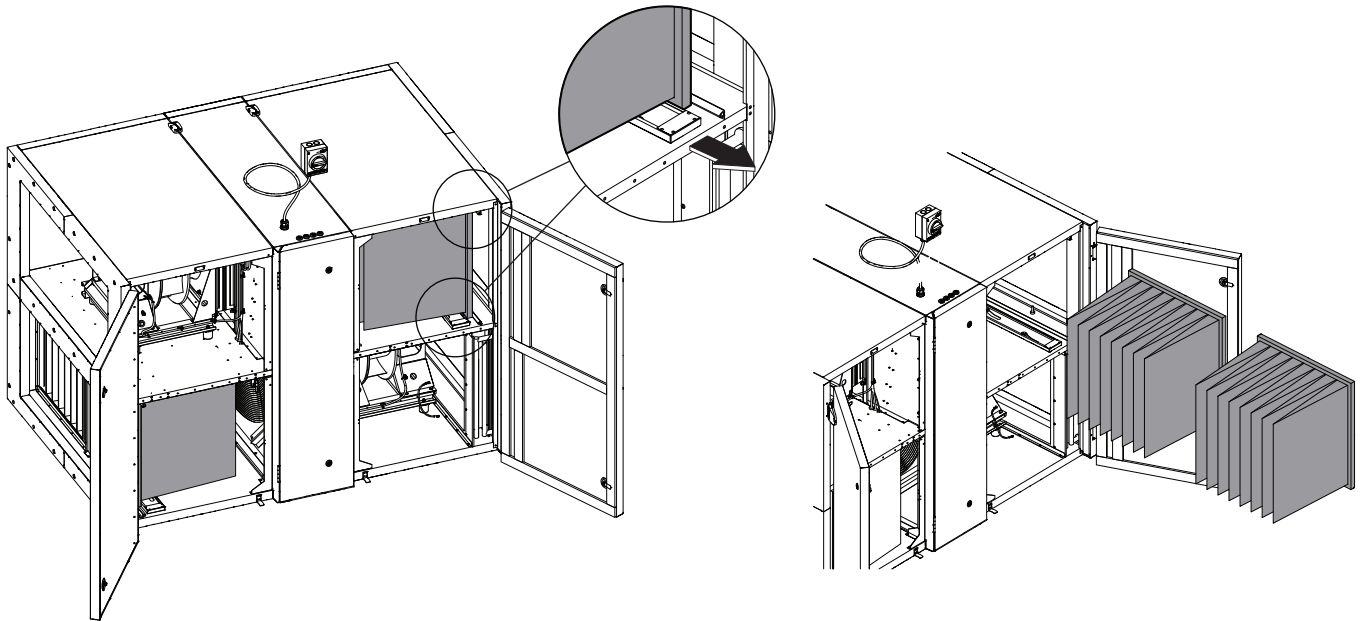

Fig. 30. An example showing how to replace bag filters



When inserting filters, make sure that their bags¹ are upright, filter frames are tightly seated and gaskets are intact.

¹ In units with bag filters.

Filters

| Unit | Filter type | Supply | | Exhaust | |
|--|-------------|-------------------|--------------------|---------------------------------|--------------------|
| | | Class | B × H × L, mm | Class | B × H × L, mm |
| VERSO R | | | | | |
| 1000 U/H/V 1300 U/H/V 1500 U/H/V | Compact | ePM1 55% (F7) | 800 × 400 × 46 | ePM10 50% (M5) ¹ | 800 × 400 × 46 |
| 1000 FSA | Compact | ePM1 55% (F7) | 472 × 402 × 96 | ePM10 50% (M5) ¹ | 472 × 402 × 96 |
| 1300 F | Compact | ePM1 55% (F7) | 410 × 420 × 46 | ePM10 50% (M5) ¹ | 410 × 420 × 46 |
| 1700 U/H/V 2000 U/H/V | Compact | ePM1 55% (F7) | 800 × 450 × 46 | ePM10 50% (M5) ¹ | 800 × 450 × 46 |
| 2000 F | Compact | ePM1 55% (F7) | 560 × 420 × 96 | ePM10 50% (M5) ¹ | 560 × 420 × 96 |
| 2500 H | Bag | ePM1 60% (F7) | 792 × 392-10 × 500 | ePM10 60% (M5) ² | 792 × 392-10 × 500 |
| 3000 U/H/V 4000 U/H/V | Compact | ePM1 55% (F7) × 2 | 525 × 510 × 46 | ePM10 50% (M5) ¹ × 2 | 525 × 510 × 46 |
| 3000 F | Compact | ePM1 55% (F7) | 560 × 540 × 96 | ePM10 50% (M5) ¹ | 560 × 540 × 96 |
| 5000 V | Compact | ePM1 55% (F7) × 2 | 650 × 630 × 92 | ePM10 50% (M5) ¹ × 2 | 650 × 630 × 92 |
| 5000 H 7000 H | Bag | ePM1 60% (F7) × 2 | 592 × 592-8 × 500 | ePM10 60% (M5) ² × 2 | 592 × 592-8 × 500 |
| 7000 V | Bag | ePM1 60% F7 × 3 | 467 × 701-8 × 500 | ePM10 60% (M5) ² × 2 | 700 × 547-8 × 320 |
| VERSO CF | | | | | |
| 1000 U/H/V 1300 U/H/V 1700 U/H/V | Compact | ePM1 55% (F7) | 800 × 400 × 46 | ePM10 50% (M5) ¹ | 800 × 400 × 46 |
| 1000 F 1300 F 1500 F | Compact | ePM1 55% (F7) | 550 × 420 × 46 | ePM10 50% (M5) ¹ | 550 × 420 × 46 |
| 2300 U/H/V | Compact | ePM1 55% (F7) | 800 × 400 × 46 | ePM10 50% (M5) ¹ | 800 × 400 × 46 |
| 2500 F | Compact | ePM1 55% (F7) | 888 × 420 × 96 | ePM10 50% (M5) ¹ | 888 × 420 × 96 |
| 3500 U/H/V | Compact | ePM1 55% (F7) × 2 | 525 × 510 × 46 | ePM10 50% (M5) ¹ × 2 | 525 × 510 × 46 |
| 5000 V | Compact | ePM1 55% (F7) × 2 | 650 × 450 × 92 | ePM10 50% (M5) ¹ × 2 | 650 × 450 × 92 |
| VERSO S | | | | | |
| 1300 F | Compact | ePM1 55% (F7) | 558 × 287 × 46 | – | – |
| 2100 F | Compact | ePM1 55% (F7) | 858 × 287 × 46 | – | – |
| 3000 F | Compact | ePM1 55% (F7) × 2 | 450 × 480 × 96 | – | – |

¹ Class ePM1 55% (F7) is available on request.

² Class ePM1 60% (F7) is available on request.

8. COMMISSIONING AND INSPECTION OF THE UNIT

Before switching on the device, check for foreign objects, debris or tools inside the unit. Make sure that air filters are installed and condensate drainage is connected (if necessary), fill the siphon with water. Make sure that the ductwork is free from obstructions such as fully closed diffusers or adjustment valves or blocked external air intake grilles.



- You may start your AHU only when it is fully installed, ducts and external electrical elements are connected. Do not start the unit without air ducts connected. This may distort air volume measurements required for stable operation of the fans.
- Do not use the unit with a temporary electrical power supply as unstable power can damage the electronic components.

See the KOMFOVENT website for user manuals.

The unit is controlled via a remote controller or a computer. The unit is supplied with the following operation modes that may be used immediately after installation or different ventilation settings may be selected.

- **COMFORT 1** – maximum ventilation intensity (100%), desired air temperature – 21°C.
- **COMFORT 2** – average ventilation intensity (50%), desired air temperature – 21°C.
- **ECONOMY 1** – low ventilation intensity (33%), desired air temperature – 20°C.
- **ECONOMY 2** – minimum ventilation intensity (20%), desired air temperature – 19°C.
- **SPECIAL** – maximum ventilation intensity (100%), desired air temperature – 21°C.
This mode may also be used to disable heating/cooling and other functions.

8.1. Control panel C5.1¹

C5.1 is control panel with coloured touch-screen for remote control of your air handling unit. This control panel is designed for indication and changing of various functions and settings of the unit.

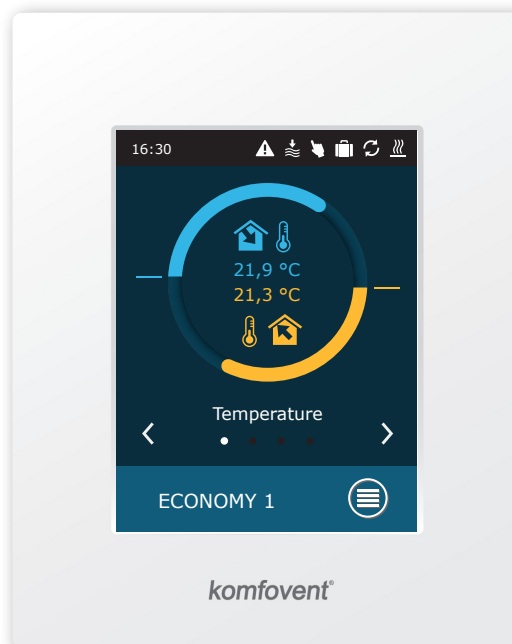
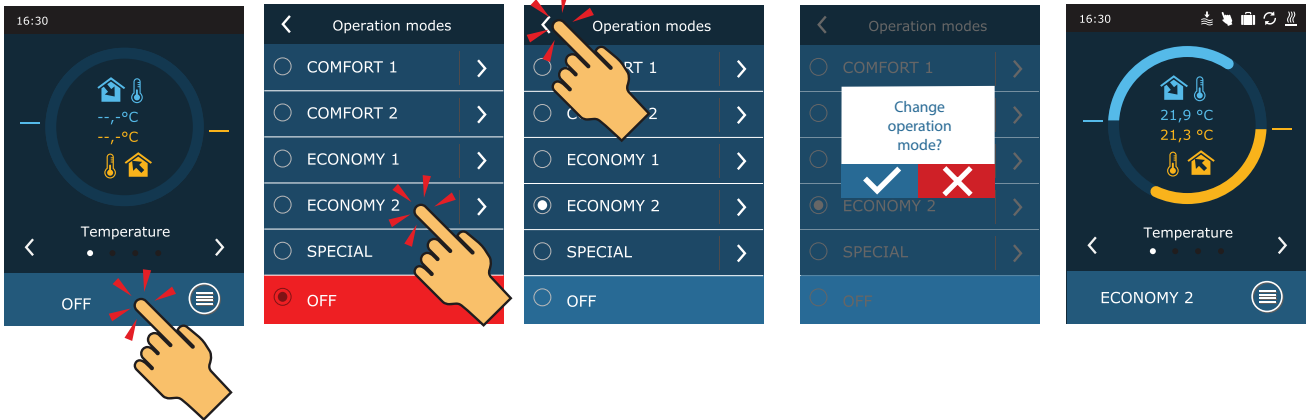

Fig. 31. Control panel

If the unit is connected to the mains, the control panel will display a home screen or a screen saver that you can switch off with a single tap.

¹ Sold separately.

To start an air handling unit or change a ventilation mode:



During the first minute of starting the unit, the unit automation checks the settings, automation components and opens air dampers. Later, a signal is sent to fans and a heat exchanger, and the unit starts operating at a selected ventilation mode.

When starting CF type AHU for the first time, it will be needed to perform heat exchanger calibration, which is used for frost prevention function.

During calibration AHU will operate for about 10 minutes on different ventilation intensities while measuring internal pressure. Thus do not open AHU doors, do not regulate duct system and do not change any settings during CF calibration. If you wish to stop calibration – turn off the unit from the control panel.



Without calibration, CF heat exchanger may get frozen and will be damaged during low outdoor temperatures.

To change the ventilation mode settings: select a desired mode and set a desired air volume or temperature with the arrows.

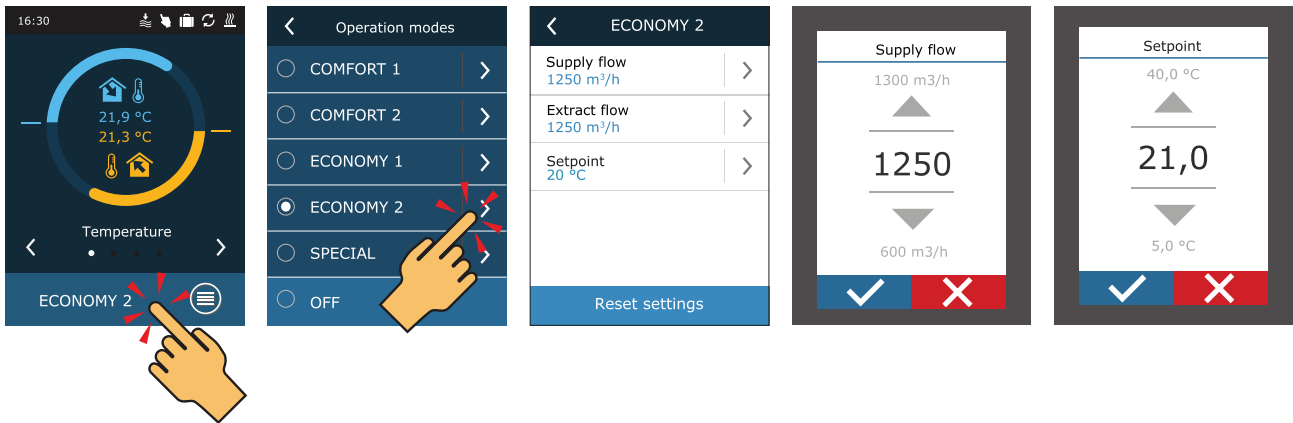

To turn of the AHU and return to a home screen:

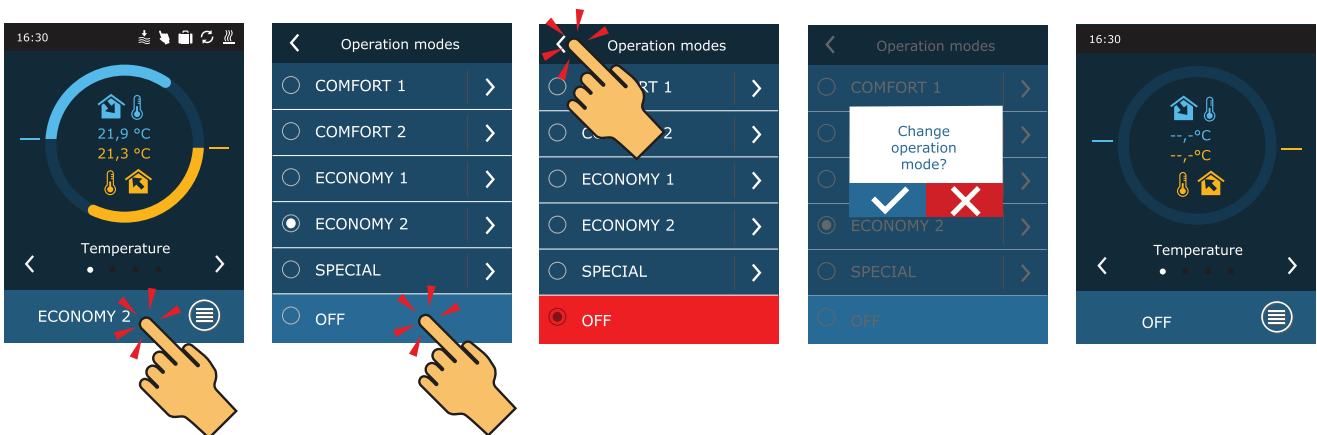

8.2. Starting the Unit With a Computer

If the unit was ordered without a control panel or it is not used, you can start it with your computer. In this case the unit is controlled via a web browser. Connect your computer directly to the AHU or to the same computer network as described in Chapter 6.5. Run the Internet browser on the computer and disable the use of all Proxy servers that may block the connection in the settings. In the web browser address bar, enter the IP address of the unit:



Login to the C5 control panel interface in a window that opens: enter the user name **user**, password **user¹** and press CONNECT.

Username: Password:

If you login attempt is successful, "Overview" window is opened.

Overview

Modes

Functions

Alarms/Status

Scheduling

Settings

The diagram shows a central vertical AHU unit with a rotation arrow. It has two horizontal air ducts. The top duct flows to the left, with a 30% damper, a temperature sensor at 8.0 °C, and a flow rate of 2000 m³/h. The bottom duct flows to the right, with a 30% damper, a temperature sensor at 27.9 °C, and a flow rate of 2000 m³/h. The AHU unit has a 100% damper and a temperature sensor at 26.5 °C. The right duct has a 10 Pa pressure sensor and a humidity sensor at 600 ppm. The top duct has a 10 Pa pressure sensor and a humidity sensor at 1200 ppm.

| | |
|------------------|---------------------------------------|
| AHU control | <input type="button" value="On/Off"/> |
| Operation mode | Economy2 |
| Active functions | |
| Alarm status | No alarms |

¹ If the password was changed, use the changed password.

To start the unit and change the ventilation mode settings:

1. Press button "Modes".
2. Select a desired ventilation mode from the list.
3. Enter desired air flow and temperature in the selected mode settings.
4. Press "Save" button at the bottom of the screen.

Overview

Modes

Functions

Alarms/Status

Scheduling

Settings

▼ OPERATION MODES

| | |
|-----------------|---|
| Mode selection | Comfort1 |
| | <ul style="list-style-type: none"> Comfort2 Economy1 <li style="background-color: #e0e0e0;">Economy2 Special Program |
| Comfort1 | |
| Supply flow | |
| Extract flow | |
| Setpoint | 21.0 °C |
| Comfort2 | |
| Supply flow | 6000 m ³ /h |
| Extract flow | 6000 m ³ /h |
| Setpoint | 21.0 °C |
| Economy1 | |
| Supply flow | 4000 m ³ /h |
| Extract flow | 4000 m ³ /h |
| Setpoint | 20.0 °C |
| Economy2 | |
| Supply flow | 2400 m ³ /h |
| Extract flow | 2400 m ³ /h |
| Setpoint | 19.0 °C |
| Special | |
| Supply flow | 12000 m ³ /h |
| Extract flow | 12000 m ³ /h |
| Setpoint | 21.0 °C |
| Heating | <input checked="" type="checkbox"/> |
| Cooling | <input checked="" type="checkbox"/> |
| Humidifying | <input checked="" type="checkbox"/> |

► FLOW CONTROL MODE

► TEMPERATURE CONTROL MODE

Save

You can stop the unit by pressing ON/OFF button in the “Overview” window.

| | |
|------------------|-----------|
| AHU control | On/Off |
| Operation mode | Economy2 |
| Active functions | AQC |
| Alarm status | No alarms |

8.3. Quick Inspection

The first time you start your device, make sure that:

| Task | Yes | No | Comments |
|---|-----|----|----------|
| Control panel is working, responds to touch, no error messages | | | |
| All air filters are installed | | | |
| Air dampers fully open | | | |
| There are no unusual noise or vibrations | | | |
| Changing the ventilation modes changes the fan speed | | | |
| The unit is airtight without gaps or air leakage | | | |
| Heating/cooling devices are working | | | |
| Connected external devices are working | | | |
| The condensate easily flows from the unit and the drainage piping is watertight | | | |
| CF heat exchanger calibration performed (only in CF units) | | | |
| Other comments: | | | |

Installer

Company

Tel. No.

Date

Signature

LITHUANIA

UAB KOMFOVENT

SERVICE AND SUPPORT

Phone: +370 5 200 8000
service@komfovent.com
www.komfovent.com

SWEDEN

Komfovent AB

Ögärdesvägen 12B
433 30 Partille, Sverige
Phone: +46 31 487 752
info_se@komfovent.com
www.komfovent.se

FINLAND

Komfovent Oy

Muuntotie 1 C1
FI-01 510 Vantaa, Finland
Phone: +358 20 730 6190
toimisto@komfovent.com
www.komfovent.com

GERMANY

Komfovent GmbH

Konrad-Zuse-Str. 2a,
42551 Velbert, Deutschland
Phone: +49 0 2051 6051180
info@komfovent.de
www.komfovent.de

LATVIA

SIA Komfovent

Bukaišu iela 1, LV-1004 Riga, Latvia
Phone: +371 24 66 4433
info.lv@komfovent.com
www.komfovent.com

Vidzemes filiāle

Alejas iela 12A, LV-4219 Valmiermuiža,
Valmieras pagasts, Burtnieku novads
Phone: +371 29 358 145
kristaps.zaicevs@komfovent.com
www.komfovent.com

PARTNERS

| | | |
|----|----------------------------------|--------------------------|
| AT | J. PICHLER Gesellschaft m. b. H. | www.pichlerluft.at |
| BE | Ventilair group | www.ventilairgroup.com |
| | ACB Airconditioning | www.acbairco.be |
| CZ | REKUVENT s.r.o. | www.rekuvent.cz |
| | WESCO AG | www.wesco.ch |
| CH | SUDCLIMATAIR SA | www.sudclimatair.ch |
| | CLIMAIR GmbH | www.climair.ch |
| DK | Øland A/S | www.oeland.dk |
| EE | BVT Partners | www.bvtpartners.ee |
| FR | ATIB | www.atib.fr |
| HR | Microclima | www.microclima.hr |
| | AIRVENT Légtechnikai Zrt. | www.airvent.hu |
| HU | Gevent Magyarország Kft. | www.gevent.hu |
| | Merkapt | www.merkapt.hu |
| IR | Fantech Ventilation Ltd | www.fantech.ie |
| IS | Blikk & Tækniþjónustan ehf | www.bogt.is |
| | Hitataekni ehf | www.hitataekni.is |
| IT | Icaria srl | www.icariavmc.it |
| | Ventilair group | www.ventilairgroup.com |
| NL | DECIPOLE-Vortvent | www.vortvent.nl |
| | CLIMA DIRECT BV | www.climadirect.com |
| NO | Ventilution AS | www.ventilution.no |
| | Ventistål AS | www.ventistal.no |
| | Thermo Control AS | www.thermocontrol.no |
| PL | Ventia Sp. z o.o. | www.ventia.pl |
| SE | Nordisk Ventilator AB | www.nordiskventilator.se |
| SI | Agregat d.o.o | www.agregat.si |
| SK | TZB produkt, s.r.o. | www.tzbprodukt.sk |