



data ventilátoru

21. 4. 2020
verze FANselect V 1.01 (200311), AMCA V 1.03 February, 2019 / 1.20.03.11 | 541 |

typ

FN035-6IL_BA.A7P2

artiklové č.

165262 | Portfolio STD-WW

technická data

motor		ECblue
napájení	-	1~ 230V 50Hz
maximální okolní teplota (t_a)	°C	55
účinnost η_{statA}	%	38,8
účinnost N_{actual} N_{SOLL}		47,2 40
ErP - třída		2015 EC regulátor integrovaný
grille influence		pressure side measured

data ventilátoru

otáčky ventilátoru (n) max. (n_{max})	1/min	- 2000
frekvence v prac.bodě (f_{DP}) (f_{max})	Hz	50 60
hmotnost výrobku (m_{Pr})	kg	8.7
zástavbové rozměry zohledněny (\bar{S} x V x H)	mm	1870 x 1230 x 2000

PF:PF_50; Ano:165262; STol:+-10 %





charakteristika / hlučnost

21. 4. 2020

verze FANselect V 1.01 (200311), AMCA V 1.03 February, 2019 / 1.20.03.11 | 541 |

1 FN035-6IL.BA.A7P2
165262 | Portfolio STD-WW

Measured in full nozzle with pressure side guard grille in air flow direction V in installation type A according to ISO5801
měřená hustota 1.16 [kg/m³]

vzduchový výkon p_{sF}

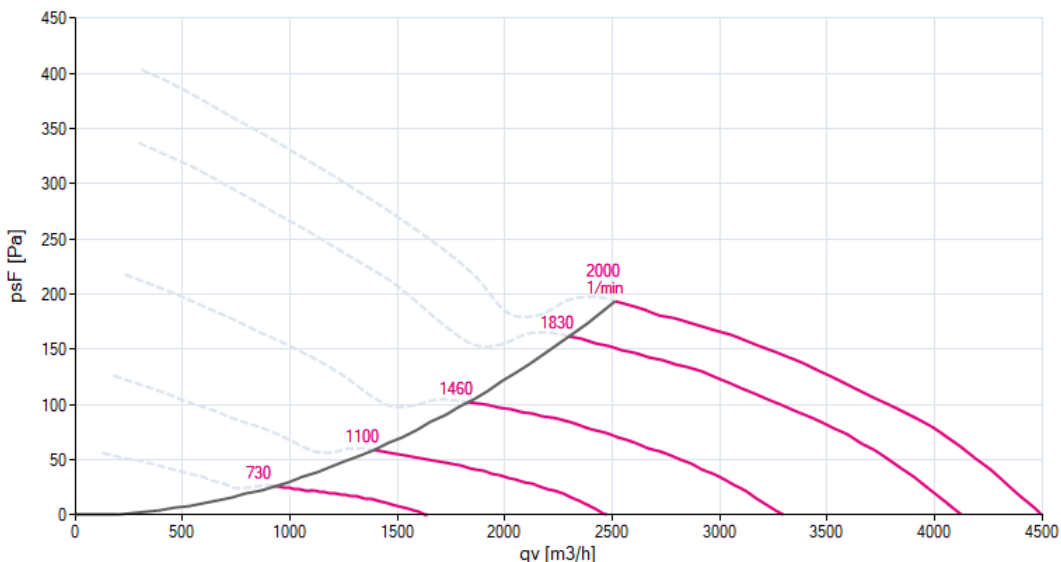

hlučnost ($L_{w(A),5}$)

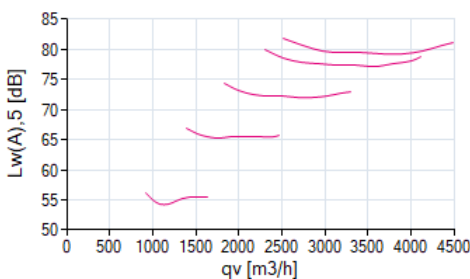

hlučnost ($L_{w(A),6}$)

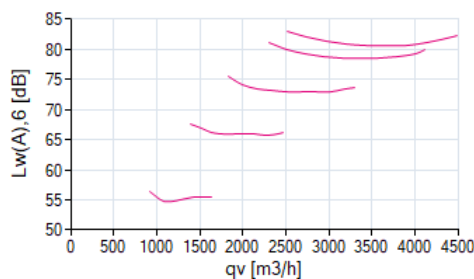

1 FN035-6IL.BA.A7P2

f [Hz]	sum	63	125	250	500	1000	2000	4000	8000	f [Hz]	sum	63	125	250	500	1000	2000	4000	8000	
$L_{w(A),5}$		-	-	-	-	-	-	-	-	$L_{w(A),6}$		-	-	-	-	-	-	-	-	-
$L_{w,5}$		-	-	-	-	-	-	-	-	$L_{w,6}$		-	-	-	-	-	-	-	-	-



účinnost / příkon

21. 4. 2020

verze FANselect V 1.01 (200311), AMCA V 1.03 February, 2019 / 1.20.03.11 | 541 |

1 FN035-6IL.BA.A7P2
165262 | Portfolio STD-WW

Measured in full nozzle with pressure side guard grille in air flow direction V in installation type A according to ISO5801
měřená hustota 1.16 [kg/m³]

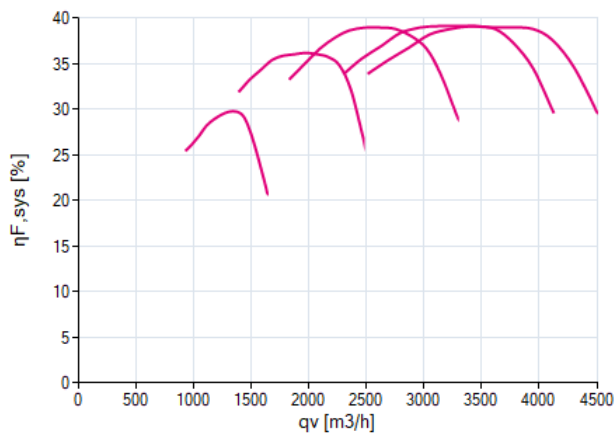
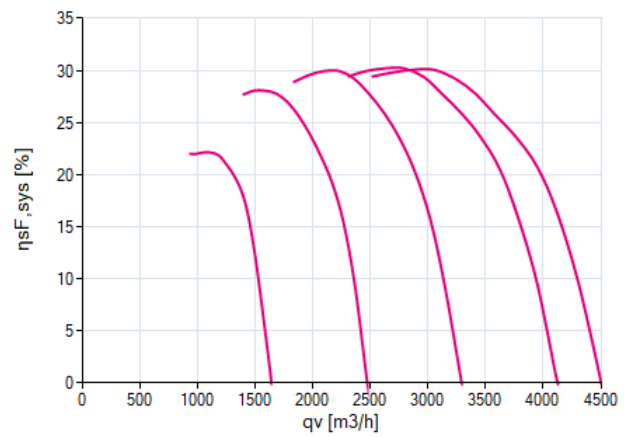
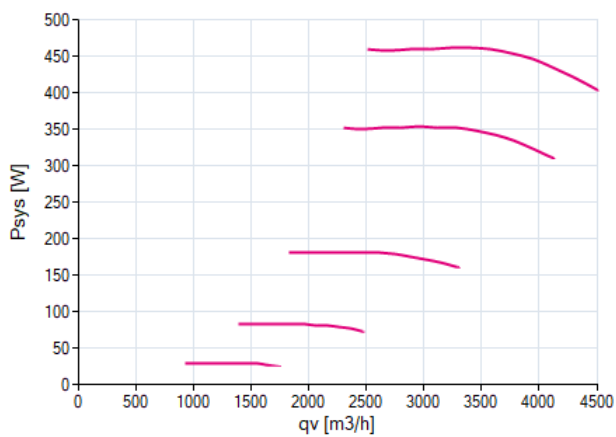
účinnost $\eta_{F,sys}$ účinnost $\eta_{sF,sys}$ příkon P_{sys} 



nominální hodnoty

21. 4. 2020

verze FANselect V 1.01 (200311), AMCA V 1.03 February, 2019 / 1.20.03.11 | 541 |

1



1" 200-277V 50Hz P1 0.46kW
 2.40-1.70A 2000/MIN 55°C
 1" 200-277V 60Hz P1 0.46kW
 2.40-1.70A 2000/MIN 55°C
 IP54 THCL155

FN035-6IL.BA.A7P2

165262

výkres

21. 4. 2020

verze FANselect V 1.01 (200311), AMCA V 1.03 February, 2019 / 1.20.03.11 | 541 |

1



FN035-6IL.BA.A7P2

165262



schéma zapojení

21. 4. 2020

verze FANselect V 1.01 (200311), AMCA V 1.03 February, 2019 / 1.20.03.11 | 541 |

1

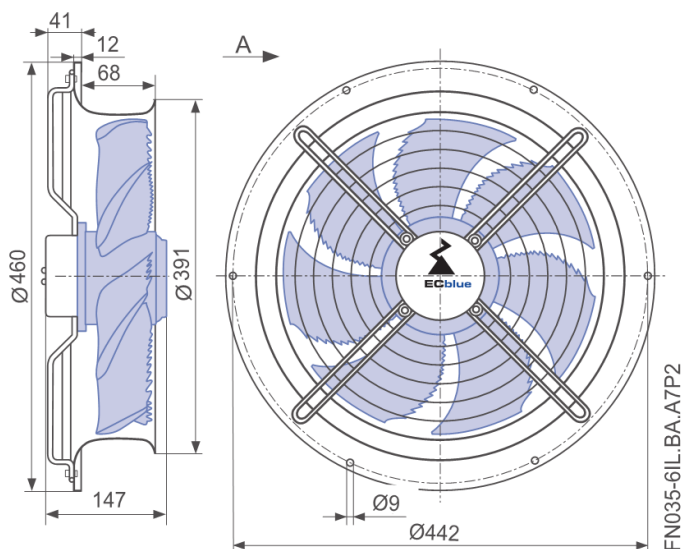

FN035-6IL.BA.A7P2

165262

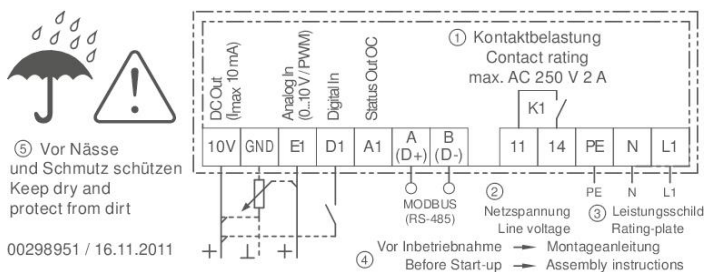



příslušenství

21. 4. 2020

verze FANselect V 1.01 (200311), AMCA V 1.03 February, 2019 / 1.20.03.11 | 541 |

typ
artiklové č.

FN035-6IL.BA.A7P2

165262

mřížkaochranná mřížka proti
dotyku
na straně výtlaku
00286215