

## data ventilátoru

21. 4. 2020

verze FANselect V 1.01 (200311), AMCA V 1.03 February, 2019 / 1.20.03.11 | 541 |

1



|              |                           |
|--------------|---------------------------|
| typ          | <b>FN071-ZIQ.GL.A7P4</b>  |
| artiklové č. | 183850   Portfolio STD-WW |

## technická data

|                                    |    |                                 |
|------------------------------------|----|---------------------------------|
| motor                              |    | ECblue                          |
| napájení                           | -  | 3~ 400V 50Hz                    |
| maximální okolní teplota ( $t_r$ ) | °C | 70                              |
| účinnost $\eta_{statA}$            | %  | 44,8                            |
| účinnost $N_{actual}$   $N_{SOLL}$ |    | <b>47,8</b>   40                |
| ErP - třída                        |    | 2015   EC regulátor integrovaný |
| grille   influence                 |    | pressure side   measured        |

## data ventilátoru

|  |       |                    |
|--|-------|--------------------|
| otáčky ventilátoru ( $n$ )   max. ( $n_{max}$ )    | 1/min | -   1400           |
| frekvence v prac.bodě ( $f_{DP}$ )   ( $f_{max}$ ) | Hz    | <b>50</b>   60     |
| hmotnost výrobku ( $m_{Pr}$ )                      | kg    | 44.7               |
| zástavbové rozměry zohledněny ( $\bar{S}$ x V x H) | mm    | 1870 x 1230 x 2000 |

PF:PF\_50; Ano:183850; STol:+-10 %



## charakteristika / hlučnost

21. 4. 2020

verze FANselect V 1.01 (200311), AMCA V 1.03 February, 2019 / 1.20.03.11 | 541 |

### 1 FN071-ZIQ.GLA7P4

Measured in full nozzle with pressure side guard grille in air flow direction V in installation type A according to ISO5801

183850 | Portfolio STD-WW

měřená hustota 1.16 [kg/m<sup>3</sup>]

### vzduchový výkon p<sub>sF</sub>

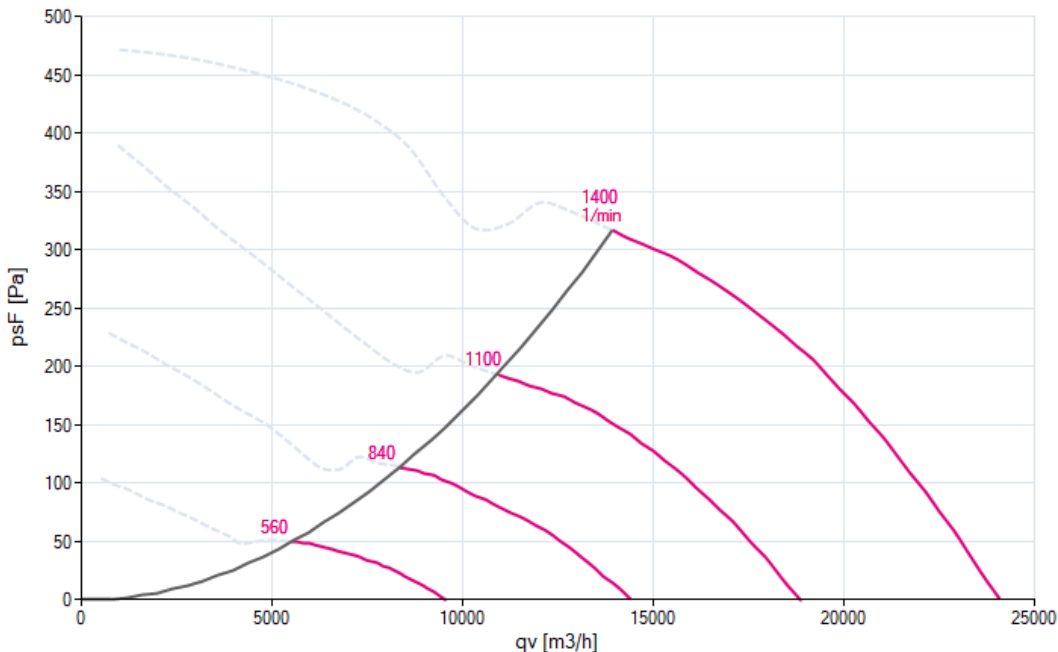

### hlučnost (L<sub>w(A),5</sub>)

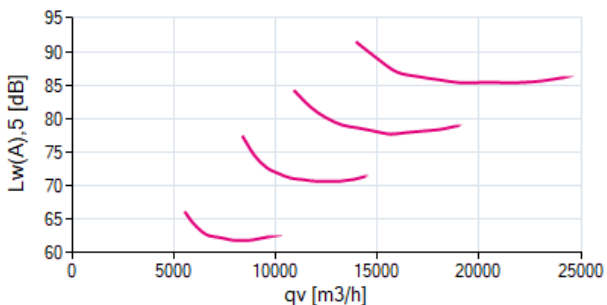

### hlučnost (L<sub>w(A),6</sub>)

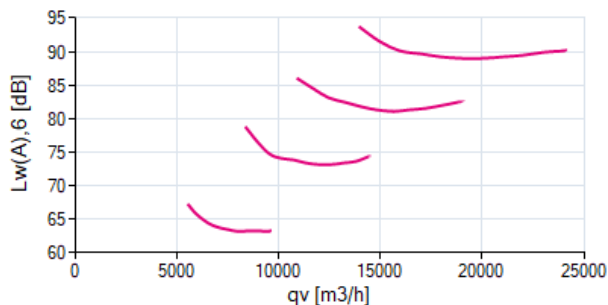

### 1 FN071-ZIQ.GLA7P4

| f [Hz]              | sum | 63 | 125 | 250 | 500 | 1000 | 2000 | 4000 | 8000 |
|---------------------|-----|----|-----|-----|-----|------|------|------|------|
| L <sub>w(A),5</sub> | -   | -  | -   | -   | -   | -    | -    | -    | -    |
| L <sub>w,5</sub>    | -   | -  | -   | -   | -   | -    | -    | -    | -    |

| f [Hz]              | sum | 63 | 125 | 250 | 500 | 1000 | 2000 | 4000 | 8000 |
|---------------------|-----|----|-----|-----|-----|------|------|------|------|
| L <sub>w(A),6</sub> | -   | -  | -   | -   | -   | -    | -    | -    | -    |
| L <sub>w,6</sub>    | -   | -  | -   | -   | -   | -    | -    | -    | -    |

1

FN071-ZIQ.GLA7P4

Measured in full nozzle with pressure side guard grille in air flow direction V in installation type A according to ISO5801

183850 | Portfolio STD-WW

měřená hustota 1.16 [kg/m³]

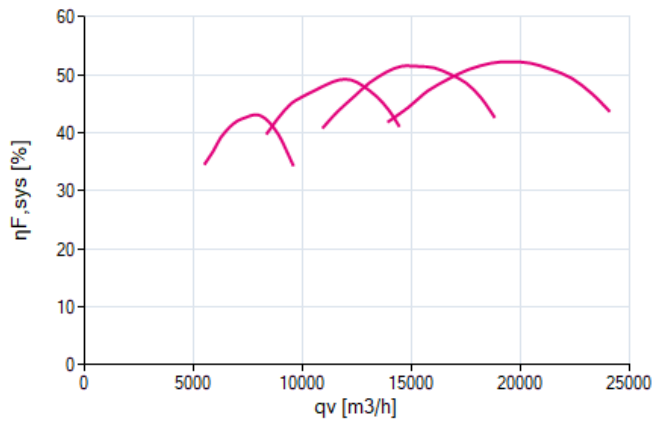
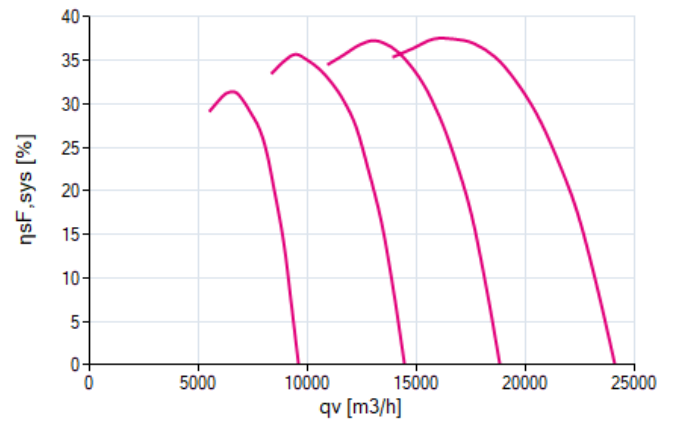
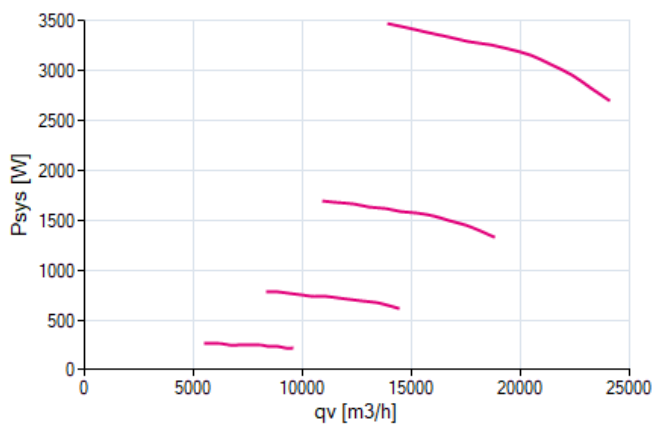
účinnost  $\eta_{F,sys}$ účinnost  $\eta_{SF,sys}$ příkon  $P_{sys}$ 



## nominální hodnoty

21. 4. 2020

verze FANselect V 1.01 (200311), AMCA V 1.03 February, 2019 / 1.20.03.11 | 541 |

1



**FN071-ZIQ.GL.A7P4**

183850

3~ 380-480V 50Hz P1 3.50kW  
 5.40-4.30A 1400/MIN 70°C  
 3~ 380-480V 60Hz P1 3.50kW  
 5.40-4.30A 1400/MIN 70°C  
 IP55 THCL155

## výkres

21. 4. 2020

verze FANselect V 1.01 (200311), AMCA V 1.03 February, 2019 / 1.20.03.11 | 541 |

1



**FN071-ZIQ.GL.A7P4**

183850

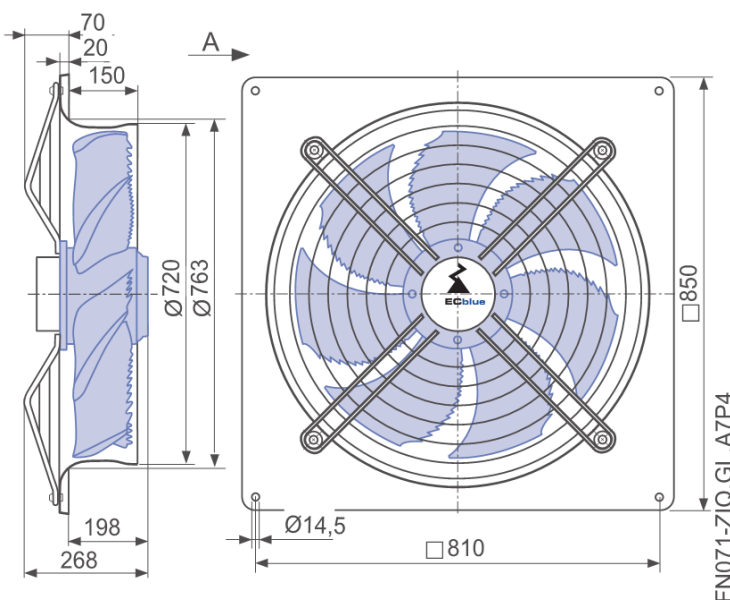

## schéma zapojení

21. 4. 2020

verze FANselect V 1.01 (200311), AMCA V 1.03 February, 2019 / 1.20.03.11 | 541 |

1



**FN071-ZIQ.GL.A7P4**

183850

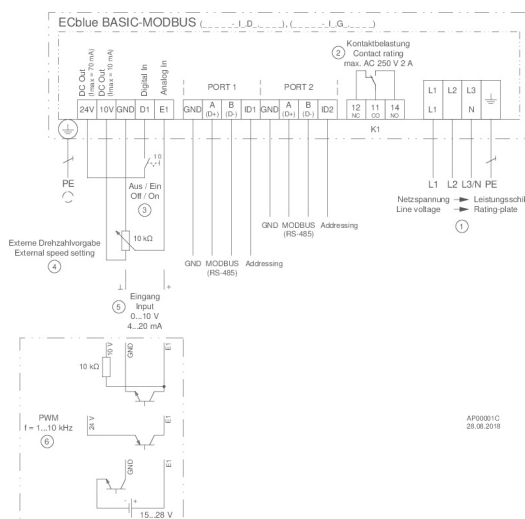



příslušenství

verze FANselect V 1.01 (200311), AMCA V 1.03 February, 2019 / 1.20.03.11 | 541 |

21. 4. 2020

1



typ

FN071-ZIQ.GL.A7P4

artiklové č.

183850